

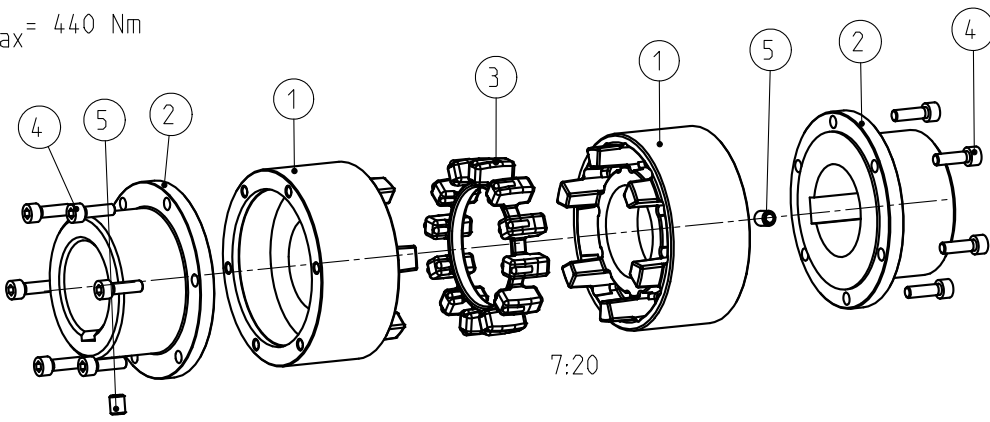

Drehmoment / Torque
 Elastomerring / elastomer ring
 NBR 78 Shore A
 $T_{KN} = 220 \text{ Nm}$
 $T_{Kmax} = 440 \text{ Nm}$

POLY-NORM	Gewicht [kg]	Massenträgheitsmoment [kgm ²]
Kuplungshälfte coupling half	2.988	0.004927
Elastomerring Elastomer ring	0.052	0.000086
Komplette Kupplung Complete coupling	6.028	0.009940



Schraubenanzugsmoment Teil 4 M6x20 DIN 912-12.9, $T_A = 14 \text{ Nm}$
 screw tightening torque part 4 M6x20 DIN 912-12.9, $T_A = 14 \text{ Nm}$

Oberflächengüte nach DIN ISO 1302 Reihe 2 Surface quality acc. to DIN ISO 1302 line 2		Schutzvermerk ISO 16016 beachten Note protection mark acc. to ISO 16016			
Allgemeintoleranzen nach DIN ISO 2768 - mH General tolerances acc. to DIN ISO 2768-		Masstab Scale	4:5	Format DIN Size	A3
POLY-NORM 48 (f. L=100) Bauart AZR			 KTR-Kupplungstechnik GmbH D-48407 Rheine		
gezeichnet drawn	Werkstoff Material	Teilnummer Part number	Kz	Lfd.-Nr. Current number	Index Change
Datum 24.08.04	DIN		M	399575	2
Name BAJ	Gewicht Weight	6.028			