

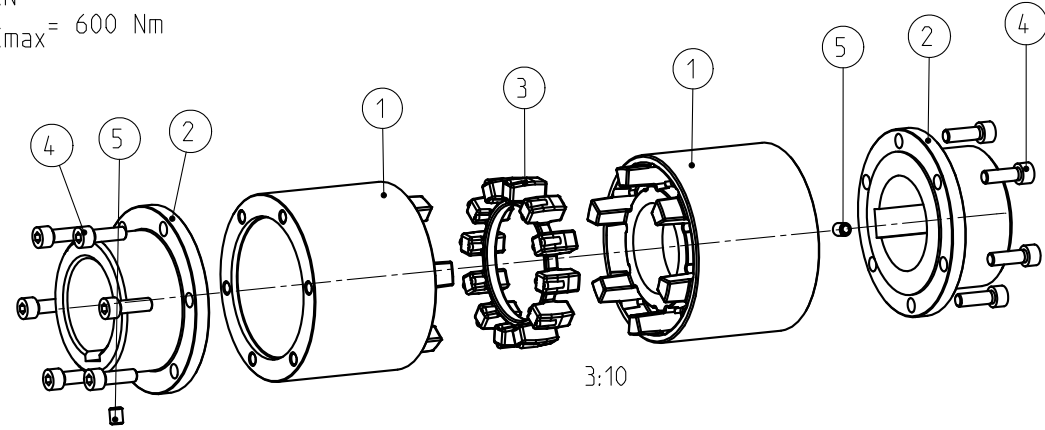

Drehmoment / Torque
 Elastomerring / elastomer ring
 NBR 78 Shore A
 $T_{KN} = 300 \text{ Nm}$
 $T_{Kmax} = 600 \text{ Nm}$

POLY-NORM	Gewicht [kg] Weight [kg]	Massenträgheitsmoment [kgm ²] Mass moment of inertia [kgm ²]
Kuplungshälfte coupling half	5.249	0.011828
Elastomerring Elastomer ring	0.071	0.000150
Komplette Kupplung Complete coupling	10.569	0.023806

Schraubenanzugsmoment Teil 4 M8x25 DIN 912-12.9, $T_A = 35 \text{ Nm}$
 screw tightening torque part 4 M8x25 DIN 912-12.9, $T_A = 35 \text{ Nm}$



Oberflächengüte nach DIN ISO 1302 Reihe 2 Surface quality acc. to DIN ISO 1302 Line 2		Schutzvermerk nach DIN 34 beachten Note protection mark acc. to DIN 34		
Allgemeintoleranzen nach DIN ISO 2768 - mH General tolerances acc. to DIN ISO 2768-		Masstab Scale	7:10	Format DIN Size
				A3
POLY-NORM 55 (f. L=180) Bauart AZR		 KTR-Kupplungstechnik GmbH D-48407 Rheine		
gezeichnet drawn	Werkstoff Material	Teilnummer Part number	Kz	Lfd.-Nr. Current number
Datum 11.07.03	DIN		M	399583
Name KO	Gewicht Weight	10.569		Index Change
				1