

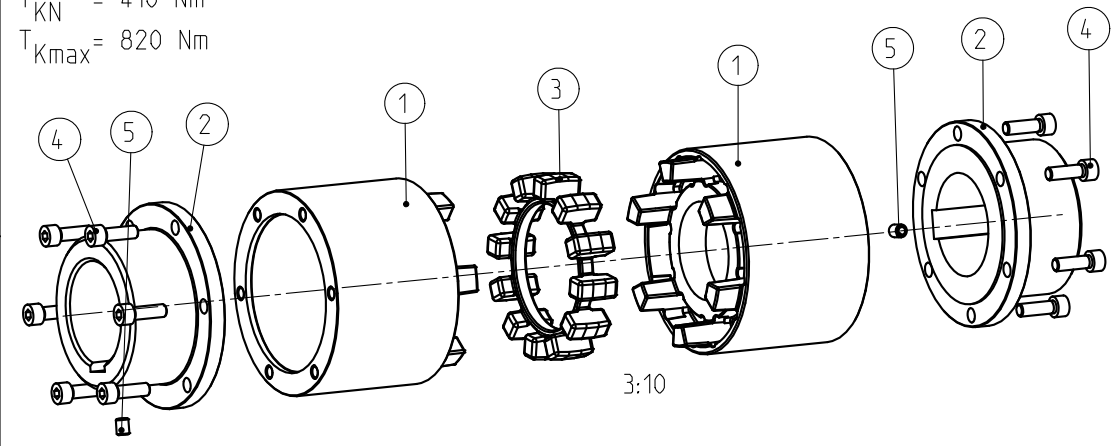

Drehmoment / Torque
 Elastomerring / elastomer ring
 NBR 78 Shore A
 $T_{KN} = 410 \text{ Nm}$
 $T_{Kmax} = 820 \text{ Nm}$

POLY-NORM	Gewicht [kg]	Massenträgheitsmoment [kgm ²]
Kuplungshälfte coupling half	6.258	0.016723
Elastomerring Elastomer ring	0.090	0.000228
Komplette Kupplung Complete coupling	12.606	0.033675



Schraubenanzugsmoment Teil 4 M8x25 DIN 912-12.9, $T_A = 35 \text{ Nm}$
 screw tightening torque part 4 M8x25 DIN 912-12.9, $T_A = 35 \text{ Nm}$

Oberflächengüte nach DIN ISO 1302 Reihe 2 Surface quality acc. to DIN ISO 1302 line 2		Schutzvermerk ISO 16016 beachten Note protection mark acc. to ISO 16016			
Allgemeintoleranzen nach DIN ISO 2768 - mh General tolerances acc. to DIN ISO 2768-		Maßstab Scale	13:20	Format DIN Size	A3
POLY-NORM 60 (f. L=180) Bauart AZR				 KTR-Kupplungstechnik GmbH D-48407 Rheine	
gezeichnet drawn	Werkstoff Material	Teilnummer Part number	Kz	Lfd.-Nr. Current number	Index Change
Datum 13.08.04	DIN		M	399657	2
Name BAJ	Gewicht Weight	12.606			