

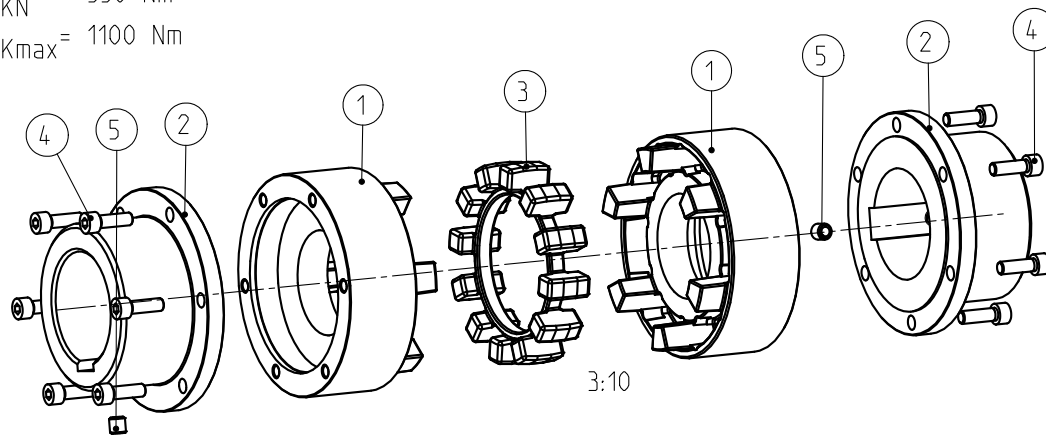

POLY-NORM	Gewicht [kg] Weight [kg]	Massenträgheitsmoment [kgm ²] Mass moment of inertia [kgm ²]
Kupplungshälfte coupling half	5.867	0.016741
Elastomerring Elastomer ring	0.112	0.000335
Komplette Kupplung Complete coupling	11.846	0.033817

Drehmoment / Torque
 Elastomerring / elastomer ring
 NBR 78 Shore A
 $T_{KN} = 550 \text{ Nm}$
 $T_{Kmax} = 1100 \text{ Nm}$



Schraubenanzugsmoment Teil 4 M8x25 DIN 912-12.9, $T_A = 35 \text{ Nm}$
 screw tightening torque part 4 M8x25 DIN 912-12.9, $T_A = 35 \text{ Nm}$

Oberflächengüte nach DIN ISO 1302 Reihe 2 Surface quality acc. to DIN ISO 1302 line 2		Schutzvermerk ISO 16016 beachten Note protection mark acc. to ISO 16016			
Allgemeintoleranzen nach DIN ISO 2768 - mH General tolerances acc. to DIN ISO 2768-		Masstab Scale	13:20	Format DIN Size	A3
POLY-NORM 65 (f. L=100) Bauart AZR			 KTR-Kupplungstechnik GmbH D-48407 Rheine		
gezeichnet drawn	Werkstoff Material	Teilnummer Part number	Kz	Lfd.-Nr. Current number	Index Change
Datum 14.07.04	DIN		M	399658	2
Name HUE	Gewicht Weight	11.846			