

Standard / standard 1
Nabenwerkstoff: EN-GJL-250
hub material: EN-GJL-250

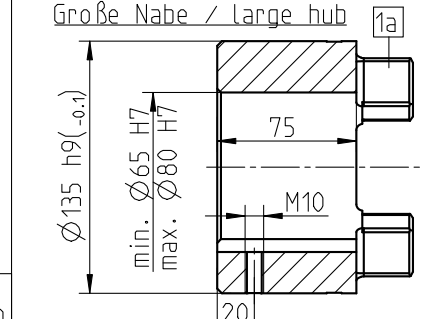

Große Nabe / large hub 1a
Nabenwerkstoff: EN-GJL-250
hub material: EN-GJL-250

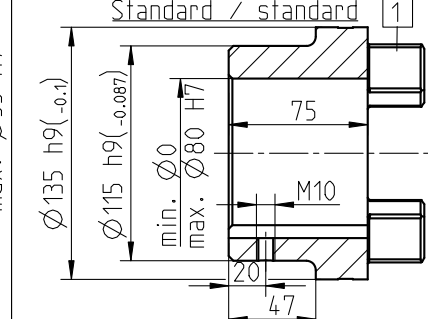

Standard / standard 1
Nabenwerkstoff: S355J2G3
hub material: S355J2G3

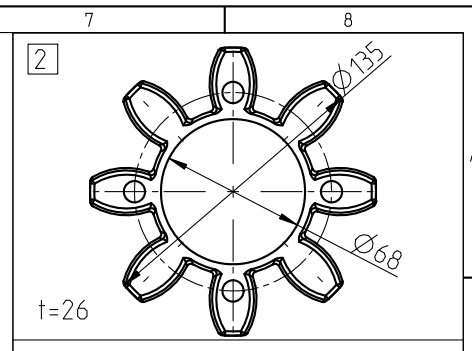

Zahnkranz/ spider
92 Sh A T-PUR orange / orange
(92 Sh A PUR gelb / yellow)
Drehmoment/ Torque
 $T_{KN} = 625Nm$
 $T_{Kmax} = 1250Nm$

Zahnkranz/ spider
95 Sh A T-PUR lila / purple
(95 Sh A PUR rot / red)
Drehmoment/ Torque
 $T_{KN} = 940Nm$
 $T_{Kmax} = 1880Nm$

Zahnkranz/ spider
64 Sh D T-PUR grün / green
64 Sh D PUR natur-weiß mit
grüner Zahnmarkierung /
natural white with
green tooth marking
Drehmoment/ Torque
 $T_{KN} = 1175Nm$
 $T_{Kmax} = 2350Nm$
Vor Einsatz Rucksprache KTR/
before inserting please consult KTR

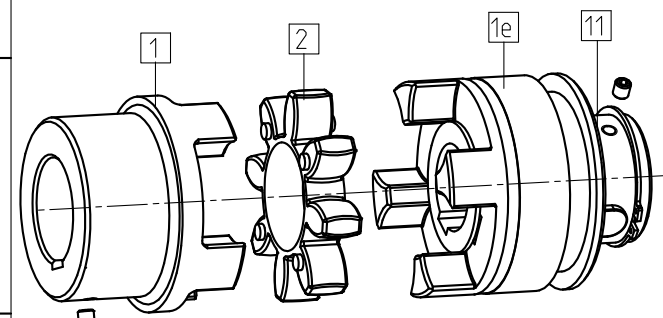

Paßfedernute nach DIN 6885 Bl. 1-JS9
keyway acc. to DIN 6885 sheet 1-JS9
passend fuer Schaltgestaenge Gr. 3 und Schleifring 3.3
suitable for shift linkage size 3 and slip ring size 3.3

SD Schaltnabe mit SD Schaltbuchse/
SD shifting hub with shifting hub SD

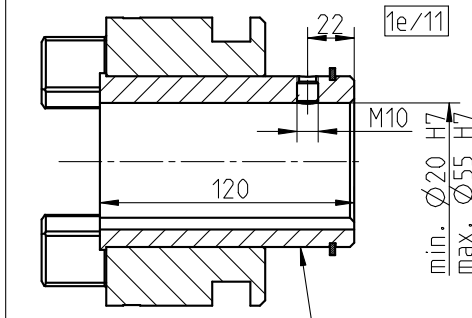

Schaltstuhl gefettet
engaging fit greased
Eingestellte Schaltkraft 280 N /
Shifting force 280 N

Massenträgheitsmoment (J_{ges}) der Kupplung (mit max. Bohrung)/
mass moment of inertia (J_{ges}) of the kupplung (with max. bore)

	SD-Schaltnabe / SD shifting hub	Standard / standard	Große Nabe / large hub	Standard / standard
Werkstoff / material	S355J2G3 (Nabe / hub) S355J2G3 (Buchse / bush)	EN-GJL-250	EN-GJL-250	S355J2G3
J_{ges}	0.0190699 kgm ²	0.0311355 kgm ²	0.0365435 kgm ²	0.0323026 kgm ²

Oberflächengüte nach DIN ISO 1302 Reihe 2
Surface quality acc. to DIN ISO 1302 line 2

Allgemeintoleranzen nach DIN ISO 2768 - mH
General tolerances acc. to DIN ISO 2768 - mH

Schutzvermerk ISO 16016 beachten
Note protection mark acc. to ISO 16016

Masstab Scale 1:2
Format DIN Size A3

ROTEX 65 SD			
gezeichnet drawn	Werkstoff Material	Teilnummer Part number	Kz
Datum 17.02.12	DIN		
Name SCHP	Gewicht Weight	22.667	

KTR-Kupplungstechnik GmbH D-48407 Rheine			
Lfd.-Nr. Current number	Index Change		
450375	1		