



ROTEX®

Torsionally flexible jaw-type
couplings types

No. 001 – shaft coupling,
No. 018 – DKM,
with taper clamping sleeve
and their combinations

according to Standard 94/9/EC
(ATEX 95) for finish bored, pilot
bored and unbored couplings

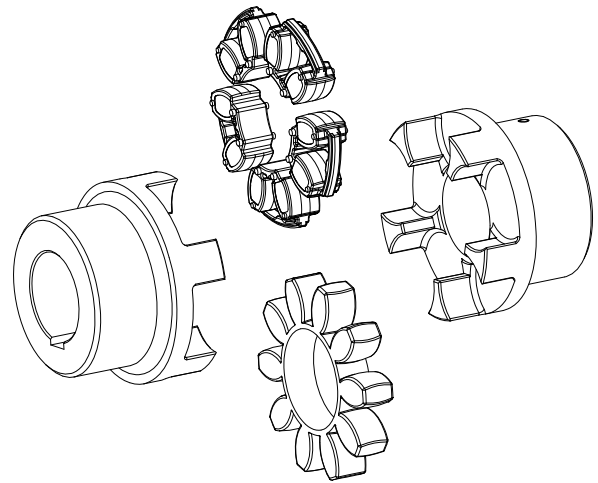

design No. 001 – shaft coupling

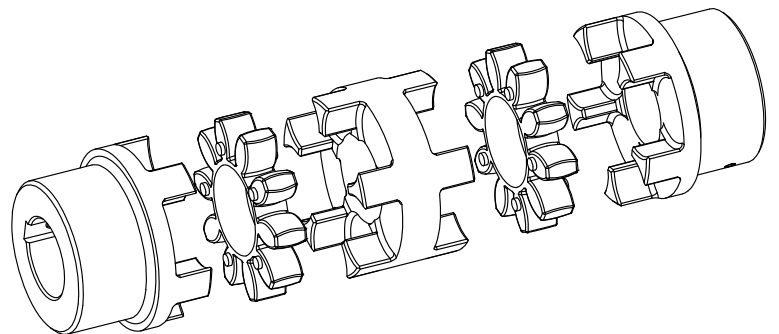

**design No. 018 – DKM
double-cardanic coupling**

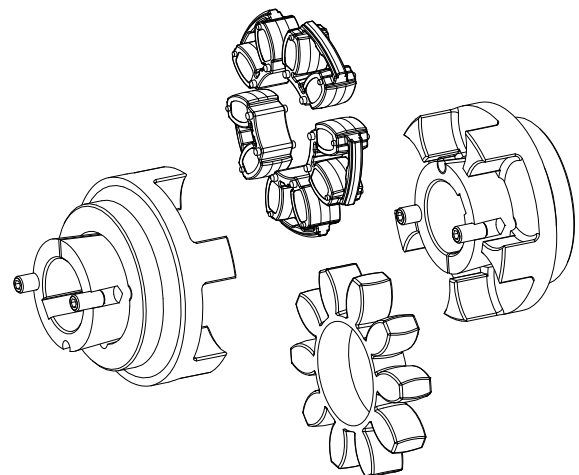

design with taper clamping sleeve



ROTEX® is a torsionally flexible jaw coupling. It is able to compensate for shaft displacement caused by, as an example, inaccuracies in production, heat expansion, etc.

Table of Contents

1 Technical Data

2 Hints

- 2.1 Coupling Selection
- 2.2 General Hints
- 2.3 Safety and Advice Hints
- 2.4 General Hints to Danger
- 2.5 Proper Use





3 Storage

4 Assembly

- 4.1 Components of the Couplings
- 4.2 Hint Regarding the Finish Bore
- 4.3 Assembly of the Hubs
- 4.4 Assembly of the Taper Clamping Sleeve
- 4.5 Displacements - Alignment of the Couplings
- 4.6 Spares Inventory, Customer Service Addresses

5 Enclosure A

Hints and Instructions Regarding the Use in Hazardous Areas

- 5.1 Use in  Hazardous Areas According to the Regulations
- 5.2 Control Intervals for Couplings in  Hazardous Areas
- 5.3 Approximate Values of Wear
- 5.4 Permissible Coupling Materials in the  Hazardous Area
- 5.5  Marking of Coupling for the Hazardous Area
- 5.6 Starting
- 5.7 Breakdowns, Causes and Elimination
- 5.8 EC Certificate of Conformity according to the EC Standards 94/9/EC dated 23 March 1994



1 Technical Data

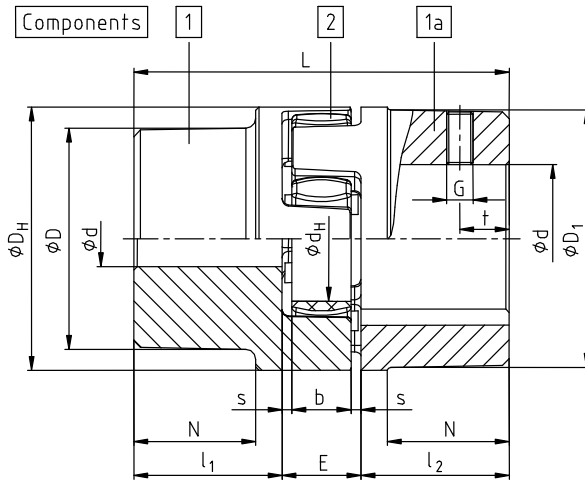

picture 1: ROTEX® (material: AI-D)

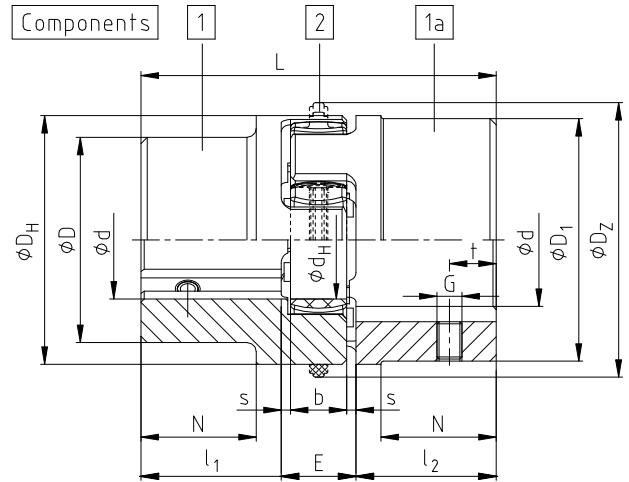

picture 2: ROTEX® (material: EN-GJL-250/EN-GJS-400-15)

Table 1: material AI-D

Size	Component	Spider ¹⁾ (component 2) rated torque [Nm]			Finish bore ²⁾ d (min-max)	Dimensions [mm] ³⁾										
		92 Sh A (yellow)	98 Sh A (red)	64 Sh D (green)		General										
					L	l ₁ ; l ₂	E	b	s	D _H	D _Z	D _{Z1} ⁴⁾	d _H	D;D ₁	N	
14	1a				6 - 16	35	11	13	10	1,5	30	-	-	10	30	-
19	1	10	17	-	6 - 19	66	25	16	12	2	41	-	-	18	32	20
	19 - 24				41											
24	1	35	60	-	9 - 24	78	30	18	14	2	56	-	-	27	40	24
	22 - 28				56											
28	1	95	160	-	10 - 28	90	35	20	15	2,5	67	-	-	30	48	28
	28 - 38				67											

Table 2: material EN-GJL-250 (GG 25)/EN-GJS-400-15 (GGG 40)

Size	Component	Spider ¹⁾ (component 2) rated torque [Nm]			Finish bore ²⁾ d (min-max)	Dimensions [mm] ³⁾										
		92 Sh A (yellow)	98 Sh A (red)	64 Sh D (green)		General										
					L	l ₁ ; l ₂	E	b	s	D _H	D _Z	D _{Z1} ⁴⁾	d _H	D;D ₁	N	
Cast iron EN-GJL-250																
38	1	190	325	405	12 - 40	114	45	24	18	3	80	-	-	38	66	37
	1a				38 - 48										78	
	1b				12 - 48										164	
42	1	265	450	560	14 - 45	126	50	26	20	3	95	-	-	46	75	40
	1a				42 - 55										94	
	1b				14 - 55										176	
48	1	310	525	655	15 - 52	140	56	28	21	3,5	105	-	-	51	85	45
	1a				48 - 62										104	
	1b				15 - 62										188	
55	1	410	685	825	20 - 60	160	65	30	22	4	120	-	-	60	98	52
	1a				55 - 74										118	
65	1	625	940	1175	22 - 70	185	75	35	26	4,5	135	-	-	68	115	61
75	1	1280	1920	2400	30 - 80	210	85	40	30	5	160	-	-	80	135	69
90	1	2400	3600	4500	40 - 97	245	100	45	34	5,5	200	218	230	100	160	81
Nodular iron EN-GJS-400-15																
100	1	3300	4950	6185	50 - 115	270	110	50	38	6	225	246	260	113	180	89
110	1	4800	7200	9000	60 - 125	295	120	55	42	6,5	255	276	290	127	200	96
125	1	6650	10000	12500	60 - 145	340	140	60	46	7	290	315	330	147	230	112
140	1	8550	12800	16000	60 - 160	375	155	65	50	7,5	320	345	360	165	255	124
160	1	12800	19200	24000	80 - 185	425	175	75	57	9	370	400	415	190	290	140
180	1	18650	28000	35000	85 - 200	475	185	85	64	10,5	420	450	465	220	325	156

- 1) maximum torque of the coupling T_{Kmax} = rated torque of the coupling T_{KNenn} x 2
- 2) bore H7 keyway to DIN 6885 sheet 1 [JS9] with thread for setscrew
- 3) dimensions G and t see table 6; threads for set screws are opposite the keyway in case of material AI-D and on the keyway in case of material EN-GJL-250/EN-GJS-400-15
- 4) D_{Z1} = internal diameter of housing

Schutzvermerk ISO 16016 beachten.	Gezeichnet:	21.05.10 Pz/Bru	Ersatz für:	KTR-N vom 13.10.09
	Geprüft:	25.05.10 Pz	Ersetzt durch:	



1 Technical Data

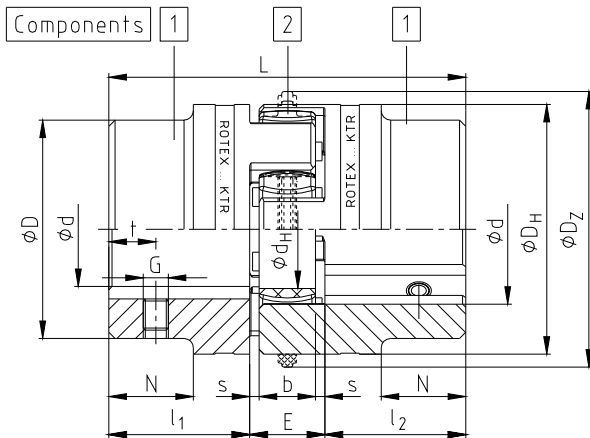

picture 3: ROTEX® (material: steel)

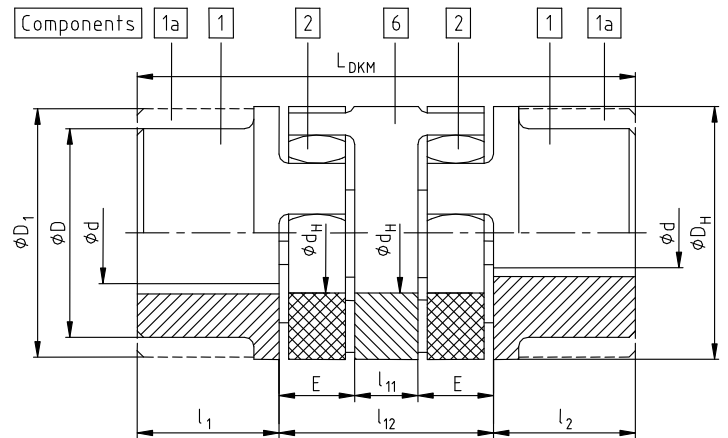

picture 4: ROTEX®, design DKM⁵⁾

Table 3: material steel

Size	Component	Spider ¹⁾ (component 2) rated torque [Nm]			Finish bore ²⁾ d (min-max)	Dimensions [mm] ³⁾										
		92 Sh A (yellow)	98 Sh A (red)	64 Sh D (green)		General										
		L	l ₁ ; l ₂	E		b	s	D _H	D _Z	D _{Z1} ⁴⁾	d _H	D	N			
14	1a				0 - 16	35	11	13	10	1,5	30	-	-	10	30	-
	1b					50	18,5									
19	1a	10	17	21	0 - 25	66	25	16	12	2	40	-	-	18	40	-
	1b															
24	1a	35	60	75	0 - 35	78	30	18	14	2	55	-	-	27	55	-
	1b															
28	1a	95	160	200	0 - 40	90	35	20	15	2,5	65	-	-	30	65	-
	1b															
38	1	190	325	405	0 - 48	114	45	24	18	3	80	-	-	38	70	27
	1b															164
42	1	265	450	560	0 - 55	126	50	26	20	3	95	-	-	46	85	28
	1b															176
48	1	310	525	655	0 - 62	140	56	28	21	3,5	105	-	-	51	95	32
	1b															188
55	1	410	685	825	0 - 74	160	65	30	22	4	120	-	-	60	110	37
	1b															210
65	1	625	940	1175	0 - 80	185	75	35	26	4,5	135	-	-	68	115	47
	1b															235
75	1	1280	1920	2400	0 - 95	210	85	40	30	5	160	-	-	80	135	53
	1b															260
90	1	2400	3600	4500	0 - 110	245	100	45	34	5,5	200	218	230	100	160	62
	1b															295

Table 4: design DKM⁵⁾

Size	Spider ¹⁾ (component 2) rated torque [Nm]		Measure d, D, D ₁	Dimensions [mm] ³⁾								
	92 Sh A (yellow)	98 Sh A (red)		General								
	L _{DKM}	l ₁ ; l ₂		E	b	s	D _H	d _H	l ₁₁	l ₁₂		
19	10	17	see table 1 to 3	92	25	16	12	2	40	18	10	42
24	35	60		112	30	18	14	2	55	27	16	52
28	95	160		128	35	20	15	2,5	65	30	18	58
38	190	325		158	45	24	18	3	80	38	20	68
42	265	450		174	50	26	20	3	95	46	22	74
48	310	525		192	56	28	21	3,5	105	51	24	80
55	410	685		218	65	30	22	4	120	60	28	88
65	625	940		252	75	35	26	4,5	135	68	32	102
75	1280	1920		286	85	40	30	5	160	80	36	116
90	2400	3600		330	100	45	34	5,5	200	100	40	130

- 1) maximum torque of the coupling $T_{Kmax.}$ = rated torque of the coupling $T_{KNenn.} \times 2$
- 2) bore H7 keyway to DIN 6885 sheet 1 [JS9] with thread for setscrew
- 3) dimensions G and t see table 6; threads for set screws are opposite the keyway in case of material Al-D and on the keyway in case of material EN-GJL-250/EN-GJS-400-15
- 4) D_{Z1} = internal diameter of housing
- 5) Type DKM not available with DZ elements.

Schutzvermerk ISO 16016 beachten.	Gezeichnet: 21.05.10 Pz/Bru	Ersatz für: KTR-N vom 13.10.09
	Geprüft: 25.05.10 Pz	Ersetzt durch:



1 Technical Data

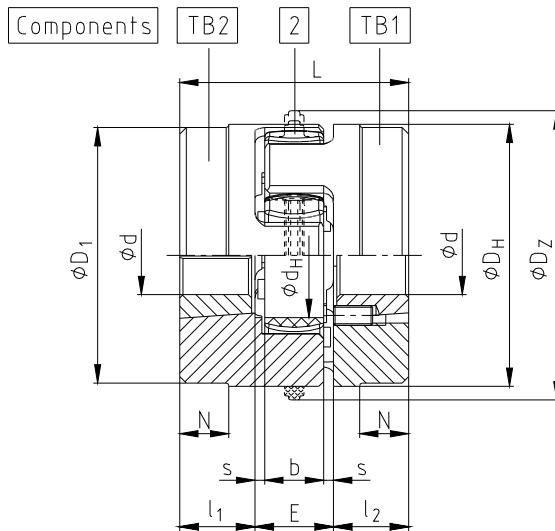

picture 5: ROTEX®, design with taper clamping sleeve

Coupling design:

- TB1 Cam-sided screwing
- TB2 Collar-sided screwing

Different combinations of types TB1 and TB2 are possible.

Table 5: design with taper clamping sleeve

Size	Component	Spider ¹⁾ (component 2) rated torque [Nm]		Finish bore d (min-max)	Dimensions [mm]												Taper clamping sleeve
		92 Sh A (yellow)	98 Sh A (red)		general												
					L	l ₁ ; l ₂	E	b	s	D _H	D _Z	D _{Z1} ²⁾	d _H	D ₁	N		
24	1a	35	60	10 - 22	64	23	18	14	2	55	-	-	27	-	-	1008	
28	1a	95	160	10 - 25	66	23	20	15	2,5	65	-	-	30	-	-	1108	
38	1a	190	325	10 - 25	70	23	24	18	3	80	-	-	38	78	15	1108	
42	1a	265	450	14 - 40	78	26	26	20	3	95	-	-	46	94	16	1610	
48	1a	310	525	14 - 40	106	39	28	21	3,5	105	-	-	51	104	28	1615	
55	1a	410	685	14 - 50	96	33	30	22	4	120	-	-	60	118	20	2012	
65	1	625	940	14 - 50	101	33	35	26	4,5	135	-	-	68	115	5	2012	
75	1	1280	1920	16 - 60	130	52	40	30	5	160	-	-	80	158	36	2517	
90	1	2400	3600	25 - 75	149	52	45	34	5,5	200	218	230	100	160	14	3020	

1) maximum torque of the coupling $T_{Kmax.}$ = rated torque of the coupling $T_{KNenn.}$ x 2
2) D_{Z1} = internal diameter of housing



ROTEX® couplings with attached parts that can generate heat, sparks and static charging (e. g. combinations with brake drums, brake disks, overload systems like torque limiters, impellers etc.) are not allowed for the use in hazardous areas. A separate checking must be made.



2 Hints

2.1 Coupling Selection



CAUTION!

For a continuous and troublefree operation of the coupling it must be designed according to the selection instructions (according to DIN 740 part 2) for the particular application (see ROTEX® catalogue).

If the operating conditions (performance, speed, changes at engine and machine) change, the coupling selection must be checked again.

Please make sure that the technical data regarding torque only refers to the spider. The transmissible torque of the shaft/hub connection must be checked by the orderer, and he is responsible for the same.

For drives with endangered torsional vibration (drives with periodical load on torsional vibration) it is necessary to make a torsional vibration calculation to ensure a perfect selection. Typical drives with endangered torsional vibration are e. g. drives with diesel engines, piston pumps, piston compressors etc. On request KTR makes the coupling selection and the torsional vibration calculation.

2.2 General Hints

Please read through these mounting instructions carefully before you set the coupling into operation. Please pay special attention to the safety instructions!



The ROTEX® coupling is suitable and approved for the use in hazardous areas. When using the coupling in hazardous areas please observe the special hints and instructions regarding safety in enclosure A.

The mounting instructions are part of your product. Please keep them carefully and close to the coupling. The copyright for these mounting instructions remains with KTR Kupplungstechnik GmbH.

2.3 Safety and Advice Hints



DANGER!

Danger of injury to persons.



CAUTION!

Damages on the machine possible.



ATTENTION!

Pointing to important items.



PRECAUTION!

Hints concerning explosion protection.



2 Hints

2.4 General Hints of Danger



DANGER!

With assembly, operation and maintenance of the coupling it has to be made sure that the entire drive train is protected against unintentional engagement. You can be seriously hurt by rotating parts. Please make absolutely sure to read through and observe the following safety instructions.

- All operations on and with the coupling have to be performed taking into account "safety first".
- Please make sure to disengage the power pack before you perform your work.
- Protect the power pack against unintentional engagement, e. g. by providing hints at the place of engagement or removing the fuse for current supply.
- Do not touch the operation area of the coupling as long as it is in operation.
- Please protect the coupling against unintentional touch. Please provide for the necessary protection devices and caps.

2.5 Proper Use

You may only assemble, operate and maintain the coupling if you

- carefully read through the mounting instructions and understood them
- had technical training
- are authorized to do so by your company

The coupling may only be used in accordance with the technical data (see table 1 to 5 in chapter 1).

Unauthorized modifications on the coupling design are not admissible. We do not take any warranty for resulting damages. To further develop the product we reserve the right for technical modifications.

The **ROTEX®** described in here corresponds to the technical status at the time of printing of these mounting instructions.

3 Storage

The coupling hubs are supplied in preserved condition and can be stored at a dry and roofed place for 6 - 9 months.

The features of the coupling spiders (elastomers) remain unchanged for up to 5 years in case of favourable stock conditions.



CAUTION!

The storage rooms may not include any ozone-generating devices, like e. g. fluorescent light sources, mercury-vapour lamps or electrical high-voltage appliances.

Humid storage rooms are not suitable.

Please make sure that there is no condensation. The best relative air humidity is under 65%.



4 Assembly

Basically the coupling is supplied in individual parts. Before assembly the coupling has to be controlled for completeness.

4.1 Components of Couplings

Components of ROTEX®, shaft coupling design No. 001

Component	Quantity	Designation
1	2	hub
2	1	spider ¹⁾
3	5 ²⁾	elements DZ ¹⁾
4	2	setscrew DIN EN ISO 4029

- 1) optionally spider or DZ elements
2) with size 180 quantity = 6

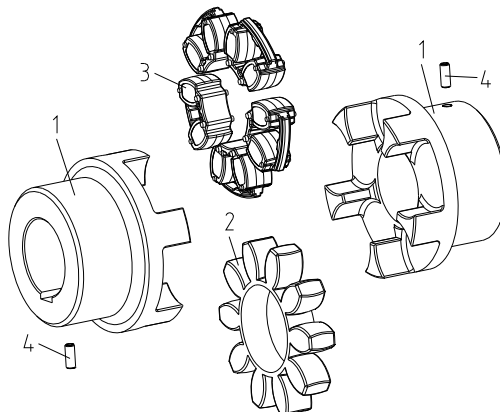

picture 6:
ROTEX®

Components of ROTEX®, DKM¹⁾

Component	Quantity	Designation
1	2	hub
2	2	spider
3	1	DKM - spacer
4	2	setscrew DIN EN ISO 4029

- 1) Type DKM not available with DZ elements.

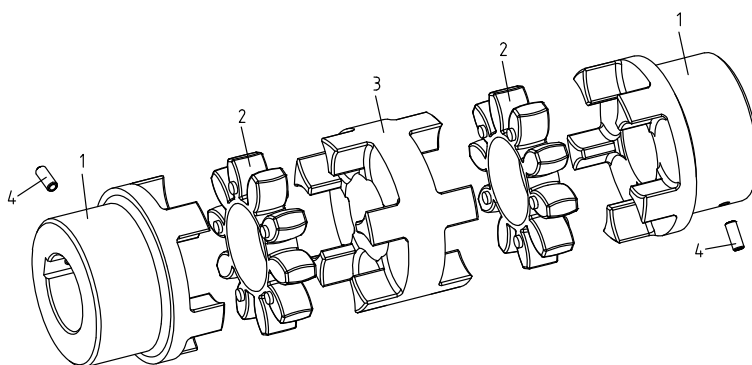

picture 7: ROTEX® DKM

Components of ROTEX®, design with taper clamping sleeve

Component	Quantity	Designation
TB1/TB2	2	hub for taper clamping sleeve
1	2	taper clamping sleeve
2	1	spider ¹⁾
3	5 ²⁾	elements DZ ¹⁾
4	4	setscrew DIN EN ISO 4029

- 1) optionally spider or DZ elements
2) with size 180 quantity = 6

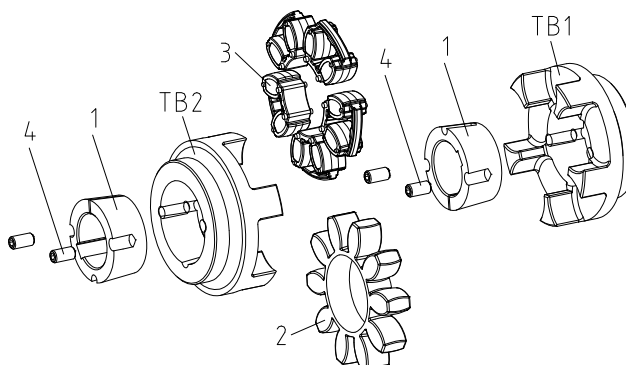

picture 8:
ROTEX®
design with
taper
clamping
sleeve

Features of the standard spiders

Spider hardness (Shore)	Marking (colour)
92 Sh A	yellow
95/98 Sh A	red
64 Sh D-F	natural white with green marking of teeth



4 Assembly

4.2 Hint Regarding the Finish Bore



DANGER!

The maximum permissible bore diameters d (see table 1 to 5 in chapter 1 - Technical Data) must not be exceeded. If these figures are disregarded, the coupling may tear. Rotating particles may cause serious danger.

- Hub bores machined by the customer have to observe concentric running or axial running, respectively (see picture 9).
- Please make absolutely sure to observe the figures for d_{max} .
- Carefully align the hubs when the finish bores are brought in.
- Please use a setscrew according to DIN EN ISO 4029 with a cup point or an end plate to fasten the hubs axially.

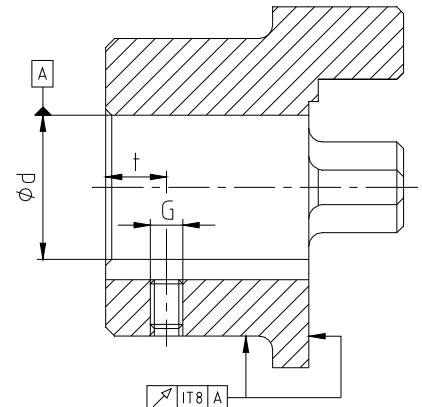

picture 9: concentric running and axial running



CAUTION!

The orderer is responsible for all subsequently made machinings to unbored or pilot bored and to finish machined coupling parts and spare parts. KTR does not assume any warranty claims resulting from insufficient refinish.



PRECAUTION!

Any mechanical rework to couplings that are used in hazardous areas require an explicit release by KTR.

The orderer must send a drawing to KTR acc. to which the manufacture must be made. KTR checks this drawing and returns it to the orderer with approval. KTR supplies unbored or pilot bored coupling parts and spare parts on explicit customer's request. These parts are additionally labelled with the symbol Ⓢ .

Table 6: setscrews DIN EN ISO 4029

Size	14	19	24	28	38	42	48	55	65	75	90	100	110	125	140	160	180
Dimension G	M4	M5	M5	M8	M8	M8	M8	M10	M10	M10	M12	M12	M16	M16	M20	M20	M20
Dimension t	5	10	10	15	15	20	20	20	20	25	30	30	35	40	45	50	50
Tightening torque T_A [Nm]	1,5	2	2	10	10	10	10	17	17	17	40	40	80	80	140	140	140

Table 7: Recommended combinations of fit acc. to DIN 748/1

Bore [mm]		Shaft tolerance	Bore tolerance
above	to		
	50	k6	H7 (KTR-Standard)
50		m6	

If a feather key is intended to be used in the hub, it should correspond to the tolerance ISO JS9 (KTR-Standard) with normal operating conditions or ISO P9 with heavy operating conditions (frequently alternating torsional direction, shock loads, etc.). Preferably the keyway should be positioned between the cams. For the axial fastening by set screws the tapping should be positioned on the keyway with the exception of AI-D which should be positioned opposite to the keyway.

The transmissible torque of the shaft/hub connection must be checked by the orderer, and he is responsible for the same.

Schutzvermerk ISO 16016 beachten.	Gezeichnet: 21.05.10 Pz/Bru	Ersatz für: KTR-N vom 13.10.09
	Geprüft: 25.05.10 Pz	Ersetzt durch:



4 Assembly

4.3 Assembly of the Hubs



ATTENTION!

We recommend to check bores, shaft, keyway and feather key for dimensional accuracy before assembly.

Heating the hubs slightly (approx. 80 °C) allows for an easier installation onto the shaft.



PRECAUTION!

Please pay attention to the danger of ignition in hazardous areas.



DANGER!

Touching the heated hubs causes burns.
We would recommend to wear safety gloves.



CAUTION!

For the assembly please make sure that the distance dimension E (see table 1 to 5) is kept to ensure that the spider can be moved axially.
Disregarding this hint may cause damage on the coupling.

- Assemble the hubs onto the shaft of driving and driven side (see picture 10).
- Insert the spider or elements DZ into the cam section of the drive- or driven sided hub.
- Move the power packs in axial direction until the dimension E is achieved (see picture 11).
- If the power packs are already firmly assembled, axial movement of the hubs on the shafts allows for adjusting the dimension E.
- Fasten the hubs by tightening the setscrews DIN EN ISO 4029 with cup point (tightening torque see table 6).



ATTENTION!

If the shaft diameters with inserted feather key are smaller than the dimension d_H (see table 1 to 5) of the spider, one or two shaft ends may protude into the spider.

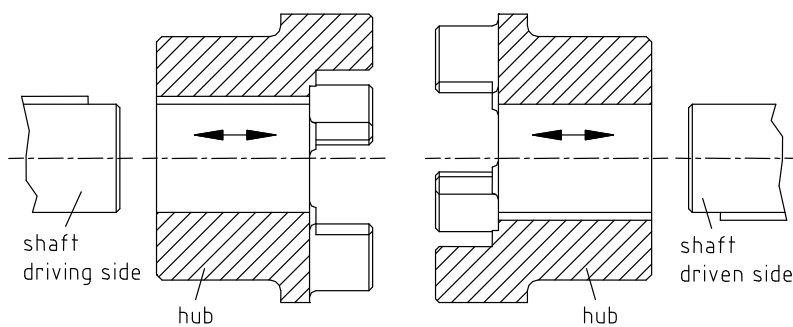

picture 10: assembly of the hubs

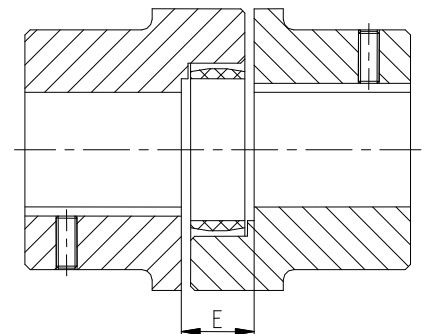

picture 11: coupling assembly



4 Assembly

4.4 Assembly of the Taper Clamping Sleeve

Assembly of the taper clamping sleeve:

The taper clamping sleeve has cylindrical and even pocket holes parallel to the axis. Only half to these holes are in the material of the sleeve. The other half located at the hub has convolutions.

Push the coupling part and the taper clamping sleeve into each other, make holes onto the cover and tighten the grub screws slightly. Push the coupling part with taper clamping sleeve onto the shaft and tighten the grub screws until reaching the tightening torque indicated in table 8.

During the screwing process the hub is pushed onto the conical sleeve and thus the sleeve is pressed onto the shaft. With light hammer strokes the taper clamping sleeve must be further pushed into the taper bore with a suitable sleeve. Afterwards please tighten the grub screws again with the tightening torque indicated in table 8. This must be made once at least.

After the drive has operated under load for a short time please check if the grub screws have untightened. An axial fixing of the taper lock hub (coupling hub with taper clamping sleeve) is only possible by a correct assembly.



CAUTION!

If used in hazardous areas the grub screws must be additionally secured against self-loosening to fix the taper clamping sleeves, e. g. glue with Loctite (medium strength). The use of taper clamping sleeves without a feather key is not permitted in hazardous areas.

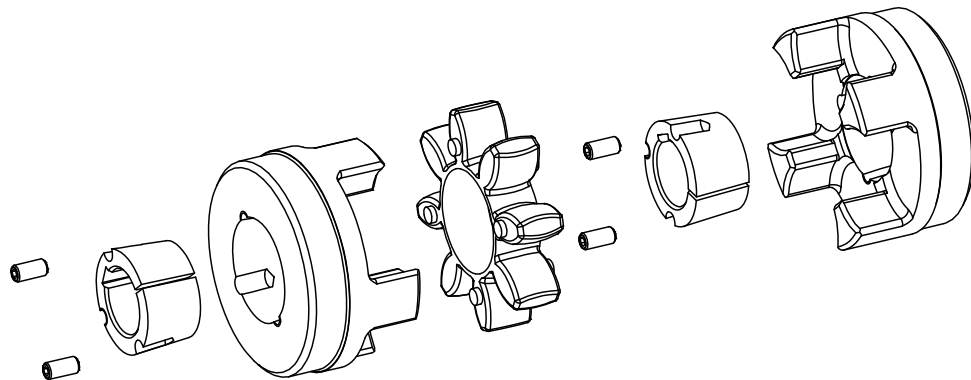

picture 12: ROTEX® design with taper clamping sleeve

Disassembly of the taper clamping sleeve:

By removing the grub screws you can detach the taper clamping sleeve. Afterwards, one of the grub screws is screwed into the thread of the sleeve as forcing screw and tightened.

The detached coupling hub can be manually taken off the shaft with the taper clamping sleeve.

Table 8:

Taper clamping sleeve	Screw dimension				Quantity	Spanner
	G [inch]	L [inch]	SW [mm]	T _A [Nm]		
1008	1/4	1/2	3	5,7	2	SW 3
1108	1/4	1/2	3	5,7	2	SW 3
1610	3/8	5/8	5	20	2	SW 5
1615	3/8	5/8	5	20	2	SW 5
2012	7/16	7/8	6	31	2	SW 6
2517	1/2	7/8	6	49	2	SW 6
3020	5/8	1 1/4	8	92	2	SW 8

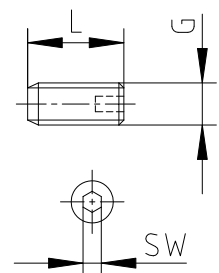

picture 13: withworth grub screw (BSW)



4 Assembly

4.5 Displacements - Alignment of the Couplings

The displacement figures shown in tables 9 and 10 offer sufficient safety to compensate for environmental influences like, for example, heat expansion or lowering of foundation.



CAUTION!

In order to ensure a long lifetime of the coupling and to avoid dangers regarding the use in hazardous areas, the shaft ends must be accurately aligned.



Please absolutely observe the displacement figures indicated (see tables 9 and 10). If the figures are exceeded, the coupling is damaged.

The exacter the alignment of the coupling, the higher is its lifetime.

In case of a use in hazardous areas for the explosion group IIC (marking II 2GD c IIC T X), only the half displacement figures (see tables 9 and 10) are permissible.

Please note:

- The displacement figures mentioned in tables 9 and 10 are maximum figures which must not arise in parallel. If radial and angular displacement arises at the same time, the permissible displacement values may only be used in part (see picture 15).
- Please check with a dial gauge, ruler or feeler whether the permissible displacement figures of tables 9 and 10 can be observed.

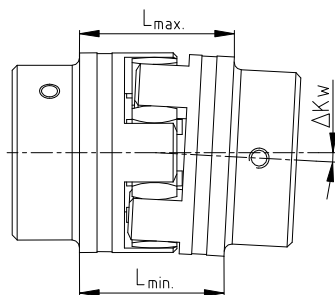

angular displacements

$$\Delta K_w = L_{1max.} - L_{1min.} \text{ [mm]}$$

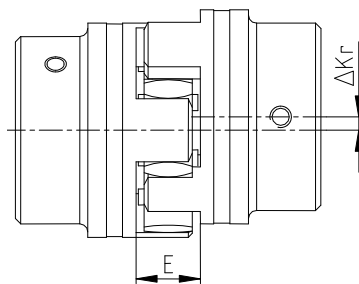

radial displacements

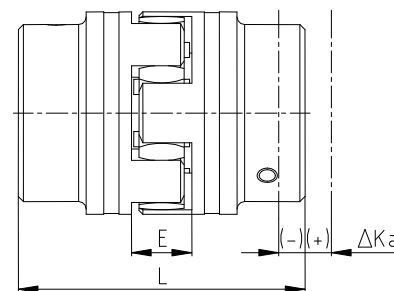

axial displacements

$$L_{max} = L + \Delta K_a \text{ [mm]}$$

picture 14: displacements

Example for the misalignment combinations given in picture 15:

Example 1:

- $\Delta K_r = 30 \%$
- $\Delta K_w = 70 \%$

Example 2:

- $\Delta K_r = 60 \%$
- $\Delta K_w = 40 \%$

$$\Delta K_{total} = \Delta K_r + \Delta K_w \leq 100 \%$$

picture 15:
combinations of
displacement

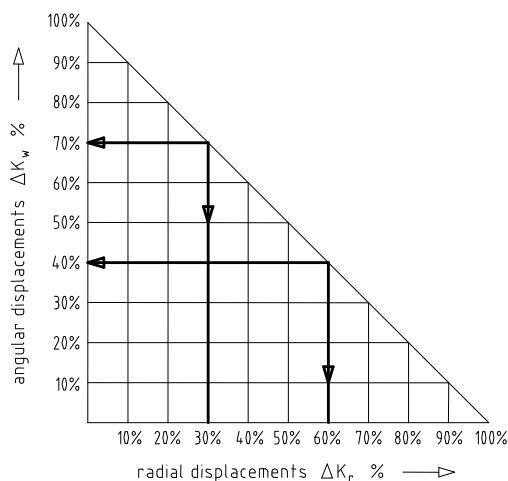



4 Assembly

4.5 Displacements - Alignment of the Couplings

Table 9: displacement figures

ROTEX® size		14	19	24	28	38	42	48	55	65	75	90	100	110	125	140	160	180
Max. axial displacement ΔK_a [mm]		-0,5	-0,5	-0,5	-0,7	-0,7	-1,0	-1,0	-1,0	-1,0	-1,5	-1,5	-1,5	-2,0	-2,0	-2,0	-2,5	-3,0
		+1,0	+1,2	+1,4	+1,5	+1,8	+2,0	+2,1	+2,2	+2,6	+3,0	+3,4	+3,8	+4,2	+4,6	+5,0	+5,7	+6,4
Max. radial displacement ΔK_r [mm] with	1500 1/min	0,17	0,20	0,22	0,25	0,28	0,32	0,36	0,38	0,42	0,48	0,50	0,52	0,55	0,60	0,62	0,64	0,68
	3000 1/min	0,11	0,13	0,15	0,17	0,19	0,21	0,25	0,26	0,28	0,32	0,34	0,36	0,38	-	-	-	-
ΔK_w [degree] max. angular displacement with $n = 1500$ 1/min		1,2	1,2	0,9	0,9	1,0	1,0	1,1	1,1	1,2	1,2	1,2	1,2	1,3	1,3	1,2	1,2	1,2
	ΔK_w [mm]	0,67	0,82	0,85	1,05	1,35	1,70	2,00	2,30	2,70	3,30	4,30	4,80	5,60	6,50	6,60	7,60	9,00
ΔK_w [degree] max. angular displacement with $n = 3000$ 1/min		1,1	1,1	0,8	0,8	0,8	0,8	0,9	1,0	1,0	1,0	1,1	1,1	1,1	-	-	-	-
	ΔK_w [mm]	0,62	0,70	0,75	0,84	1,10	1,40	1,60	2,00	2,30	2,90	3,80	4,20	5,00	-	-	-	-

Table 10: displacement figures only for design DKM

ROTEX® size		19	24	28	38	42	48	55	65	75	90
Max. axial displacement ΔK_a [mm]		+1,2	+1,4	+1,5	+1,8	+2,0	+2,1	+2,2	+2,6	+3,0	+3,4
		-1,0	-1,0	-1,4	-1,4	-2,0	-2,0	-2,0	-2,0	-3,0	-3,0
Max. radial displacement ΔK_r [mm] with $n =$	1500 1/min	0,54	0,53	0,60	0,77	0,84	1,00	1,11	1,40	1,59	1,78
	3000 1/min	0,50	0,47	0,53	0,61	0,67	0,82	1,01	1,17	1,33	1,63
ΔK_w [degree] max. angular displacement with $n =$	1500 1/min	1,20	0,90	0,90	1,00	1,00	1,10	1,10	1,20	1,20	1,20
	3000 1/min	1,10	0,80	0,80	0,80	0,80	0,90	1,00	1,00	1,00	1,10

4.6 Spares Inventory, Customer Service Addresses

A basic requirement to guarantee the operational readiness of the coupling is a stock of the most important spare parts on site.

Contact addresses of the KTR partners for spare parts and orders can be obtained from the KTR homepage under www.ktr.com.

Schutzvermerk ISO 16016 beachten.	Gezeichnet:	21.05.10 Pz/Bru	Ersatz für:	KTR-N vom 13.10.09
	Geprüft:	25.05.10 Pz	Ersetzt durch:	



5 Enclosure A

Hints and Instructions Regarding the Use in Hazardous Areas

design 001: hub / spider / hub or hub / elements DZ / hub
 design 018: hub / spider / DKM spacer / spider / hub
 design with taper clamping sleeve: hub / taper clamping sleeve / spider / taper clamping sleeve / hub or
 hub / taper clamping sleeve / elements DZ / taper clamping sleeve / hub
(Use of taper clamping sleeve only in connection with a feather key!)

ROTEX® DKM and ROTEX® ZS-DKM only with spacer from steel or aluminium semifinished-products with a yield point of $R_{p0,2} \geq 250 \text{ N/mm}^2$.

5.1 Use in Hazardous Areas According to the Regulations

Conditions of operation in hazardous locations

ROTEX® couplings are suitable for the use according to EC standard 94/9/EC.

1. Industry (with the exception of mining)

- device class II of category 2 and 3 (*coupling is not approved for device class 1*)
- media class G (*gases, fogs, steams*), zone 1 and 2 (*coupling is not approved for zone 0*)
- media class D (*dusts*), zone 21 and 22 (*coupling is not approved for zone 20*)
- explosion class IIC (*explosion class IIA and IIB are included in IIC*)

Temperature class:

Temperature class	ambient or operating temperature T_a	max. surface temperature
T4, T3, T2, T1	- 30 °C to + 90 °C ¹⁾	110 °C ²⁾
T5	- 30 °C to + 80 °C	100 °C
T6	- 30 °C to + 65 °C	85 °C

Explanation:

The maximum surface temperatures result from each the maximum permissible ambient or operating temperature T_a plus the maximum temperature increase ΔT of 20 K which has to be taken into account.

- 1) The ambient or operating temperature T_a is limited to + 90 °C due to the permissible permanent operating temperature of the elastomers used.
- 2) The maximum surface temperature of 110 °C applies for the use in locations which are potentially subject to dust explosion, too.

2. Mining

Device class I of category M2 (*coupling is not approved for device category M1*).
 Permissible ambient temperature - 30 °C to + 90 °C.



5 Enclosure A

Hints and Instructions Regarding the Use in  Hazardous Areas

5.2 Control Intervals for Couplings in  Hazardous Areas

explosion group	control intervals
3G 3D	For couplings which are classified in category 3G or 3D the operating and assembly instructions that are usual for standard operation apply. During the standard operation which has to be subject to the analysis of danger of ignition the couplings are free from any ignition source. Merely the temperature increase produced by proper heating and depending on the coupling type has to be considered: for ROTEX®: $\Delta T = 20 \text{ K}$
II 2GD c IIB T4, T5, T6	A checking of the circumferential backlash and a visual check of the flexible spider/elements DZ must be effected after 3,000 operating hours for the first time, after 6 months at the latest. Except for centered, stiff connecting flanges (e. g. bellhousings). If you note an unconsiderable or no wear at the spider/elements DZ after this first inspection, the further inspections can be effected, in case of the same operating parameters, respectively after 6,000 operating hours or after 18 months at the latest. If you note a considerable wear during the first inspection, so that a change of the spider/elements DZ would be recommended, please find out the cause according to the table „Breakdowns“, as far as possible. The maintenance intervals must be adjusted according to the changed operating parameters.
II 2GD c IIC T4, T5, T6	A checking of the circumferential backlash and a visual check of the flexible spider/elements DZ must be effected after 2,000 operating hours for the first time, after 3 months at the latest. Except for centered, stiff connecting flanges (e. g. bellhousings). If you note an unconsiderable or no wear at the spider/elements DZ after this first inspection, the further inspections can be effected, in case of the same operating parameters, respectively after 4,000 operating hours or after 12 months at the latest. If you note a considerable wear during the first inspection, so that a change of the spider/elements DZ would be recommended, please find out the cause according to the table „Breakdowns“, as far as possible. The maintenance intervals must be adjusted according to the changed operating parameters.

ROTEX® coupling

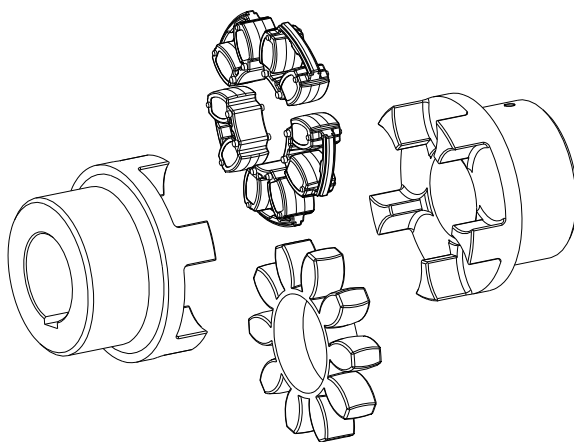

picture 16: ROTEX® coupling

picture 17.1:
ROTEX®
elements DZ

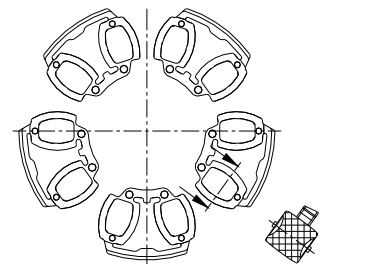

picture 17.2:
ROTEX®
spider

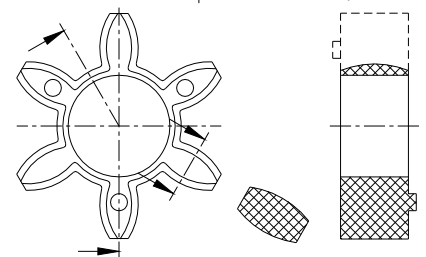

Here the backlash between coupling cams and the flexible spider/element DZ must be checked by a feeler gauge.

When reaching the limit of wear of max. friction, the spider/element DZ must be exchanged immediately, independent of the inspection intervals.

Schutzvermerk ISO 16016 beachten.	Gezeichnet: 21.05.10 Pz/Bru	Ersatz für: KTR-N vom 13.10.09
	Geprüft: 25.05.10 Pz	Ersetzt durch:



5 Enclosure A

Hints and Instructions Regarding the Use in  Hazardous Areas

5.3 Approximate Values of Wear

In case of a backlash of more than X mm, the flexible spider/elements DZ must be exchanged.

The reaching of the exchange values depends on the operating conditions and the existing operating parameters.



CAUTION!

In order to ensure a long lifetime of the coupling and to avoid dangers regarding the use in hazardous areas, the shaft ends must be accurately aligned.

Please absolutely observe the displacement figures indicated (see tables 9 and 10). If the figures are exceeded, the coupling is damaged.

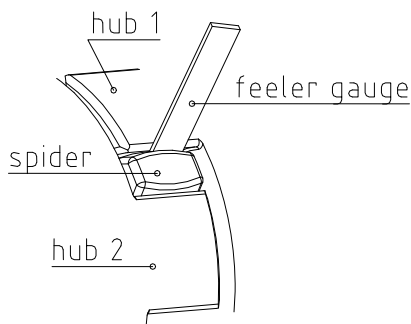

picture 18: checking of the limit of wear

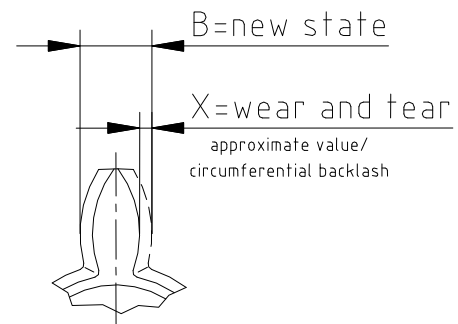

picture 19: wear of spider

Table 11:

ROTEX® size	limits of wear (friction)		ROTEX® size	limits of wear (friction)	
	X _{max.} [mm]			X _{max.} [mm]	
9	2		65	5	
14	2		75	6	
19	3		90	8	
24	3		100	9	
28	3		110	9	
38	3		125	10	
42	4		140	12	
48	4		160	14	
55	5		180	14	

5.4 Permissible Coupling Materials in the  Hazardous Area

In the Explosion Groups **IIA**, **IIB** and **IIC** the following materials may be combined:

- EN-GJL-250 (GG 25)
- EN-GJS-400-15 (GGG 40)
- steel
- stainless steel

Semifinished products from aluminium with a magnesium part of up to 7,5 % and a yield point of $R_{p0,2} \geq 250 \text{ N/mm}^2$ are permitted for the use in hazardous areas.

Aluminium diecast is generally excluded for hazardous areas.

Schutzvermerk ISO 16016 beachten.	Gezeichnet: 21.05.10 Pz/Bru	Ersatz für: KTR-N vom 13.10.09
	Geprüft: 25.05.10 Pz	Ersetzt durch:



5 Enclosure A

Hints and Instructions Regarding the Use in  Hazardous Areas

5.5 Marking of Coupling for the Hazardous Area

Couplings for the use in hazardous areas are marked on at least one component completely and on the remaining components at the outside diameter of the hub or on the front side with an  label for the respectively permitted conditions of use. The flexible spider or elements DZ is excluded.

For reason of the limited space only the symbol  is stamped up to size 19.

Complete labelling:



II 2G c IIC T6, T5 bzw. T4 - $30\text{ °C} \leq T_a \leq +65\text{ °C}$, + 80 °C bzw. +90 °C
II 2D c T 110 °C/I M2 c - $30\text{ °C} \leq T_a \leq +90\text{ °C}$

Short labelling:



II 2GD c IIC T X/I M2 c X

The former marking
remains valid:



II 2G c IIC T4/T5/T6 - $30\text{ °C} \leq T_a \leq +80/60/45\text{ °C}$
II 2D c T 110 °C/I M2 c - $30\text{ °C} \leq T_a \leq +80\text{ °C}$

The labelling with Explosion Group IIC includes the Explosion Groups IIA and IIB.

If the coupling part is labelled with  in addition to , KTR supplied it unbored or pilot bored.



CAUTION!

Any mechanical rework to couplings that are used in hazardous areas require an explicit release by KTR.

The orderer must send a drawing to KTR acc. to which the manufacture must be made. KTR checks this drawing and returns it to the orderer with approval.

5.6 Starting

Before putting the coupling into operation, check the tightness of the setscrews in the hubs, the alignment and the distance dimension E and correct, if necessary, and also check all screw connections regarding the stipulated tightening torques dependent on the type of coupling.



If used in hazardous areas the grub screws to fix the hub as well as all screw connections must be additionally secured against self-loosening, e. g. glue with Loctite (medium strength).

Last but not least, the coupling protection against unintended contact must be fixed.

The cover must be electrically conductive and be included in the equipotential bonding. Bellhousings (magnesium part below 7,5 %) made from aluminium and damping rings (NBR) can be used as connecting element between pump and electro motor. The cover may only be taken off after having stopped the unit.

During operation, please pay attention to

- strange running noises
- occurring vibrations.

If the couplings are used in dust explosive areas and in mining the user must make sure that there is no accumulation of dust in a critical quantity between the cover and the coupling. The coupling must not operate in an accumulation of dust.



5 Enclosure A

Hints and Instructions Regarding the Use in Hazardous Areas

5.6 Starting

For covers with unlocked openings on the upper side no light metals may be used if the couplings are used as appliances of appliance group II (*if possible, from stainless steel*).

If the couplings are used in mining (appliance group I M2), the cover must not be made from light metal. In addition, it must be resistant to higher mechanical loads than if it is used as appliance of appliance group II.

The minimum distance „Sr“ between the protection device and the rotating parts must at least correspond to the figures mentioned below.

If the protection device is used as cover, regular openings complying with the explosion protection demands can be made that must not exceed the following dimensions:

Openings	Cover [mm]		
	Top side	Lateral parts	Distance „Sr“
Circular - max. diameter	4	8	≥ 10
Rectangular - max. lateral length	4	8	≥ 10
Straight or curved slot - max. lateral length/height	prohibited	8	≥ 20



CAUTION!

If you note any irregularities at the coupling during operation, the drive unit must be turned off immediately. The cause of the breakdown must be found out with the table „Breakdowns“ and, if possible, be eliminated according to the proposals. The possible breakdowns mentioned can be hints only. To find out the cause all operating factors and machine components must be considered.

Coupling layer:



If coated (priming, painting etc.) couplings are used in hazardous areas, the requirements to conductability and layer thickness must be considered. In case of paintings up to 200 µm no electrostatic load can be expected. Multiple coatings that are thicker than 200 µm are prohibited for explosion group IIC.

5.7 Breakdowns, Causes and Elimination

The below-mentioned errors can lead to an incorrect use of the **ROTEX®** coupling. In addition to the stipulations in these operating and mounting instructions please make sure to avoid these errors.

The errors listed can only be clues to search for the errors. When searching for the error the adjacent components must be generally included.



Due to incorrect use the coupling can become a source of ignition. EC Standard 94/9/EC requires a special care from the manufacturer and the user.

General errors incorrect use

- Important data for the coupling selection was not forwarded.
- The calculation of the shaft/hub connection was not considered.
- Coupling parts with damage occurred during transport are assembled.
- If the heated hubs are assembled, the permissible temperature is exceeded.
- The fits of the parts to be assembled are not coordinated with each other.
- Tightening torques are below/exceeded.
- Components are exchanged by mistake/put together incorrectly.
- A wrong or no spider/elements DZ is inserted into the coupling.

Schutzvermerk ISO 16016 beachten.	Gezeichnet: 21.05.10 Pz/Bru	Ersatz für: KTR-N vom 13.10.09
	Geprüft: 25.05.10 Pz	Ersetzt durch:



5 Enclosure A

Hints and Instructions Regarding the Use in  Hazardous Areas

5.7 Breakdowns, Causes and Elimination

Continuation:

- No original KTR parts (purchased parts) are used.
- Old/already worn out spiders/elements DZ or spiders/elements DZ stored too long are used.
- The coupling used/the coupling protection used is not suitable for the operation in hazardous areas and does not correspond to EC Standard 94/9/EC, respectively.
- Maintenance intervals are not observed.

breakdowns	causes	danger hints for hazardous areas	elimination
change of the running noises and/or occurring vibrations	misalignment	increased temperature the the spider surface; danger of ignition by hot surfaces	1) put the unit out of operation 2) eliminate the reason for the misalignment (e. g. loose foundation bolts, break of the engine fixing, heat expansion of unit components, change of the assembly dimension E of the coupling) 3) checking of wear see under point Control
	wear of spider, short-term torque transmission due to metal contact	danger of ignition due to sparking	1) put the unit out of operation 2) disassemble the coupling and remove rests of the spider 3) check coupling parts and exchange damaged coupling parts 4) insert spider, assemble coupling parts 5) check alignment, correct if necessary
	loose screws for axial securement of hubs	danger of ignition due to hot surfaces and sparking	1) put the unit out of operation 2) check alignment of coupling 3) tighten the screws to secure the hubs and secure against self-loosening 4) checking of wear see under point Control
break of cam	wear of spider, torque transmission due to metal contact	danger of ignition due to sparking	1) put the unit out of operation 2) change complete coupling 3) check alignment
	break of the cams due to high shock energy/overload	danger of ignition due to sparking	1) put the unit out of operation 2) change complete coupling 3) check alignment 4) find out the reason of overload
	operating parameters do not correspond to the performance of the coupling	danger of ignition due to sparking	1) put the unit out of operation 2) check the operating parameters and select a larger coupling (consider installation space) 3) assemble new coupling size 4) check alignment
	mistake in service of the unit	danger of ignition due to sparking	1) put the unit out of operation 2) change complete coupling 3) check alignment 4) instruct and train the service staff



5 Enclosure A

Hints and Instructions Regarding the Use in  Hazardous Areas

5.7 Breakdowns, Causes and Elimination

breakdowns	causes	danger hints for hazardous areas	elimination
premature wear of spider	misalignment	increased temperature the the spider surface; danger of ignition by hot surfaces	1) put the unit out of operation 2) eliminate the reason for the misalignment (e. g. loose foundation bolts, break of the engine fixing, heat expansion of unit components, change of the assembly dimension E of the coupling) 3) checking of wear see under point Control
	e. g. contact with aggressive liquids/oils, ozone-influence, too high/low ambient temperatures etc. effecting a physical change of the spider	danger of ignition due to sparking in case of metallic contact of the cams	1) put the unit out of operation 2) disassemble the coupling and remove rests of the spider 3) check coupling parts and exchange damaged coupling parts 4) insert spider, assemble coupling parts 5) check alignment, correct if necessary 6) make sure that further physical changes of the spider are excluded
	ambient/contact temperatures which are too high for the spider, max. permissible e. g. T4 = - 30 °C/+ 90 °C	danger of ignition due to sparking in case of metallic contact of the cams	1) put the unit out of operation 2) disassemble the coupling and remove rests of the spider 3) check coupling parts and exchange damaged coupling parts 4) insert spider, assemble coupling parts 5) check alignment, correct if necessary 6) check and regulate ambient/contact temperature (eventually even elimination by using other spider materials)
premature wear of spider (liquefaction of material inside the spider cam)	drive vibrations	danger of ignition due to sparking in case of metallic contact of the cams	1) put the unit out of operation 2) disassemble the coupling and remove rests of the spider 3) check coupling parts and exchange damaged coupling parts 4) insert spider, assemble coupling parts 5) check alignment, correct if necessary 6) find out the reason for the vibrations (eventually elimination by spider with lower or higher shore hardness)



If you operate with a worn spider/elements DZ (see item 5.2) and the subsequent contact of metal parts a due operation meeting the explosion protection requirements and acc. to Standard 94/9/EC is not ensured.



ATTENTION!

KTR does not assume any liabilities or guarantees regarding the use of spare parts and accessories which are not provided by KTR and for the damages resulting herefrom.



KTR Kupplungstechnik
GmbH
D-48407 Rheine

ROTEX®
Operating-/Assembly instructions

KTR-N 40210 EN
sheet: 21 of 21
edition: 16

5 Enclosure A

Hints and Instructions Regarding the Use in  Hazardous Areas

5.8 EC Certificate of Conformity

EC Certificate of Conformity

corresponding to EC Standard 94/9/EC dated 23 March 1994
and to the legal regulations

The manufacturer - KTR Kupplungstechnik GmbH, D-48432 Rheine - states that the

flexible ROTEX® couplings

described in these mounting instructions and explosion-proof designed correspond to Article 1 (3) b) of Standard 94/9/EC and comply with the general Safety and Health Requirements according to enclosure II of Standard 94/9/EC.

According to article 8 (1) of Standard 94/9/EC the technical documentation is deposited with the:

IBExU
Institut für Sicherheitstechnik GmbH
Fuchsmühlenweg 7

09599 Freiberg

Rheine, 30.09.08
Date

i. V. _____
Reinhard Wibbeling
Engineering Manager

i. V. _____
Michael Brüning
Product Manager

Schutzvermerk ISO 16016 beachten.	Gezeichnet: 21.05.10 Pz/Bru	Ersatz für: KTR-N vom 13.10.09
	Geprüft: 25.05.10 Pz	Ersetzt durch: