

- Pos.11: DIN912 M10x35
- Pos.9: O-Ring: 515x3
- Pos.8: O-Ring: 474x14
- Pos.7: Schraube / screw DIN 908: M10x1
- Pos.6: Scheibe / disc DIN 7603: A10x13.5

Schraubenanzugsmoment (Pos.3) $T_A = 1000\text{Nm}$ Drehmoment / torque $T_{KN} = 380000\text{ Nm}$
 screw tightening torque (Pos.3) $T_A = 1000\text{Nm}$ $T_{Kmax.} = 760000\text{ Nm}$

ACHTUNG / ATTENTION
 Schrauben bei Auslieferung handfest angezogen.
 Screws are not tightened at delivery.

Oberflächenguete nach DIN ISO 1302 Reihe 2 Surface quality acc. to DIN ISO 1302 line 2		Schutzvermerk ISO 16016 beachten Note protection mark acc. to ISO 16016	
Allgemeintoleranzen nach DIN ISO 2768 - mH General tolerances acc. to DIN ISO 2768 - mH		Masstab Scale	11:50
		Format DIN Size	A3

GEARex 90 Ø350 Ø350
Bauart DAB



KTR-Kupplungstechnik
GmbH
D-48407 Rheine

gezeichnet drawn	Werkstoff Material	Teilnummer Part number	Kz	Lfd.-Nr. Current number	Index Change
Datum 30.08.11	DIN		M	543144	0
Name SCHP	Gewicht Weight	567.539			

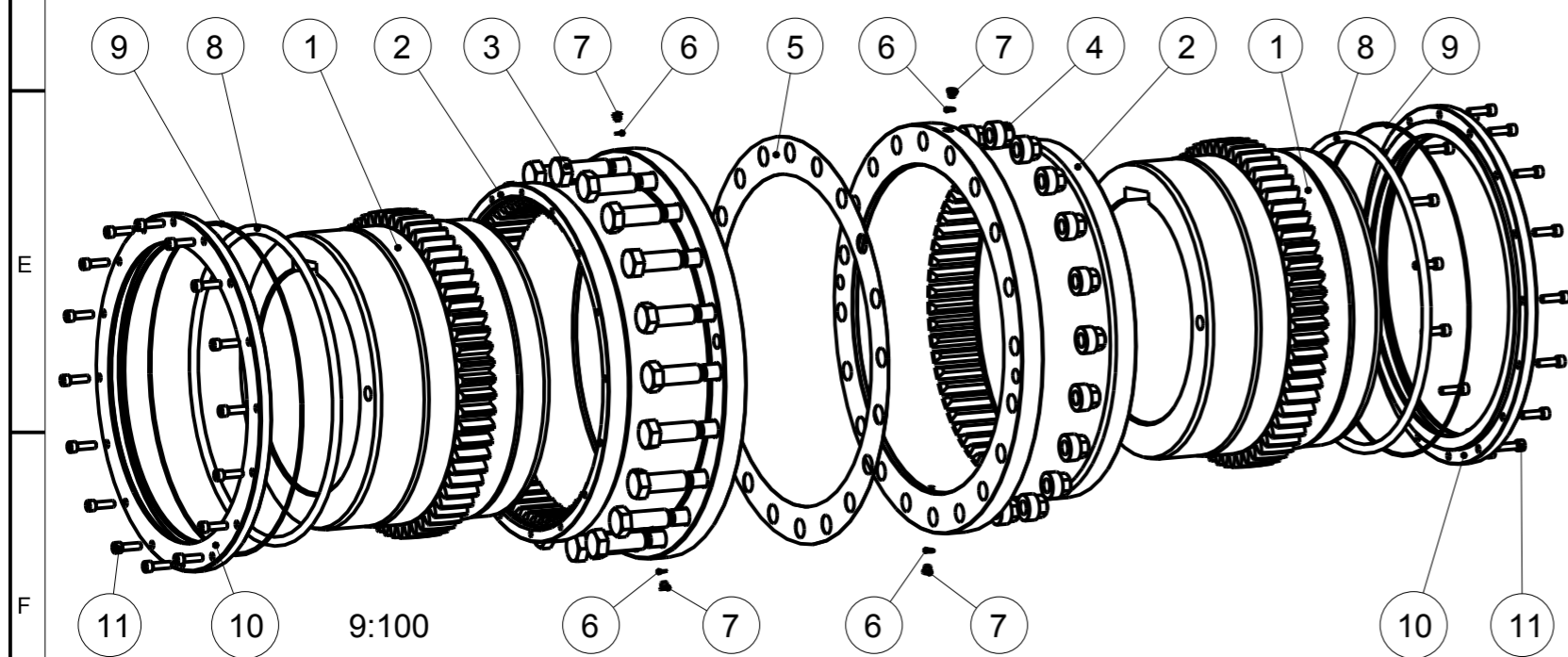

Für Montage, Betrieb & Wartung, Betriebs-/ Montageanleitung KTR-N 40310 beachten.
 For assembly, operation & maintenance, observe operating-/ assembly instructions KTR-N 40310.