

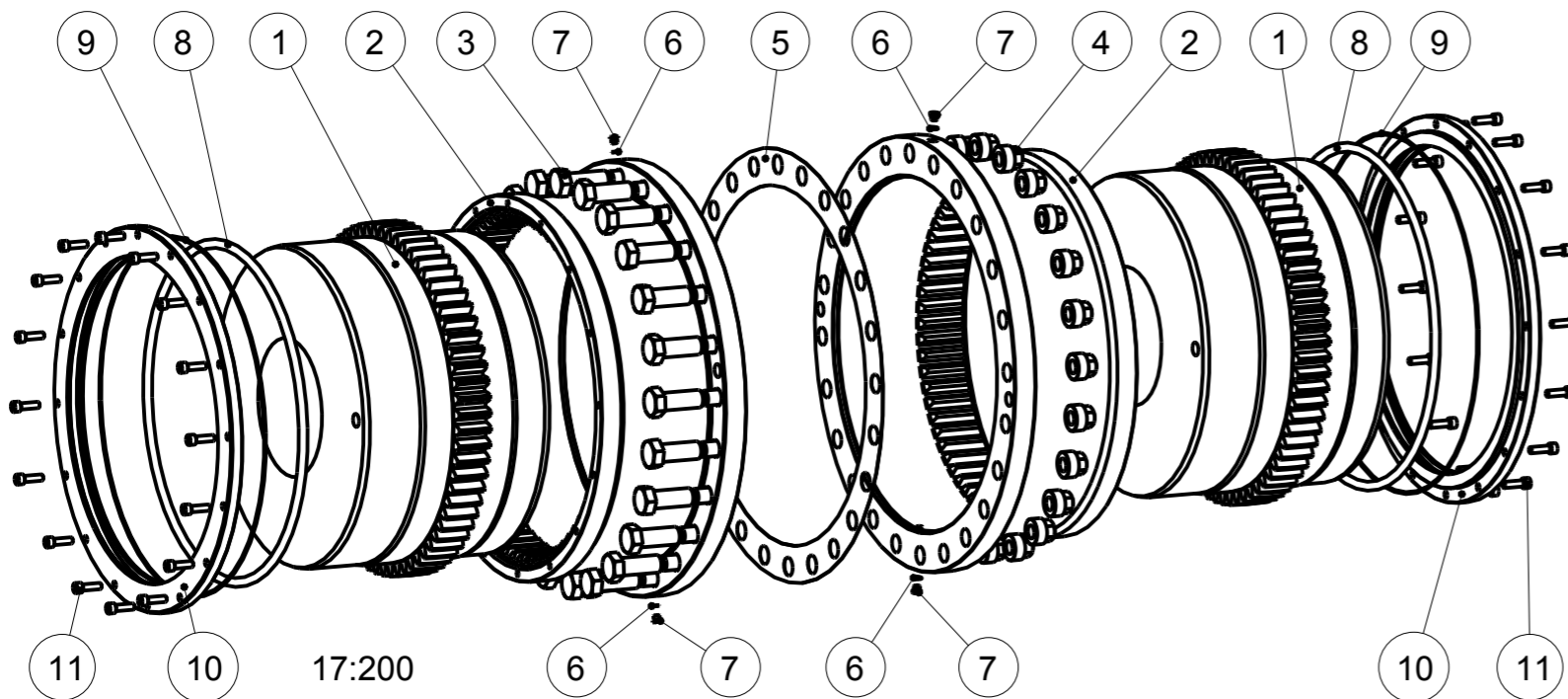

- Pos.11: DIN912 M10x35
 - Pos.9: O-Ring: 565x3
 - Pos.8: O-Ring: 522x14
 - Pos.7: Schraube / screw DIN 908: M10x1
 - Pos.6: Scheibe / disc DIN 7603: A10x13.5
- Schraubenanzugsmoment (Pos.3) $T_A = 1000\text{Nm}$ Drehmoment / torque $T_{KN} = 500000\text{ Nm}$
 screw tightening torque (Pos.3) $T_A = 1000\text{Nm}$ $T_{Kmax.} = 1000000\text{ Nm}$
- ACHTUNG / ATTENTION**
 Schrauben bei Auslieferung handfest angezogen.
 Screws are not tightened at delivery.



Oberflächenguete nach DIN ISO 1302 Reihe 2 Surface quality acc. to DIN ISO 1302 line 2		Schutzvermerk ISO 16016 beachten Note protection mark acc. to ISO 16016			
Allgemeintoleranzen nach DIN ISO 2768 - mH General tolerances acc. to DIN ISO 2768 - mH		Masstab Scale	1:5	Format DIN Size	A3
GEARex 100 Ø220 Ø220 Bauart DAB			 KTR-Kupplungstechnik GmbH D-48407 Rheine		
gezeichnet drawn	Werkstoff Material	Teilnummer Part number	Kz	Lfd.-Nr. Current number	Index Change
Datum 15.08.11	DIN		M	542027	0
Name KU	Gewicht Weight	1128.801			

Für Montage, Betrieb & Wartung, Betriebs-/ Montageanleitung KTR-N 40310 beachten.
 For assembly, operation & maintenance, observe operating-/ assembly instructions KTR-N 40310.