

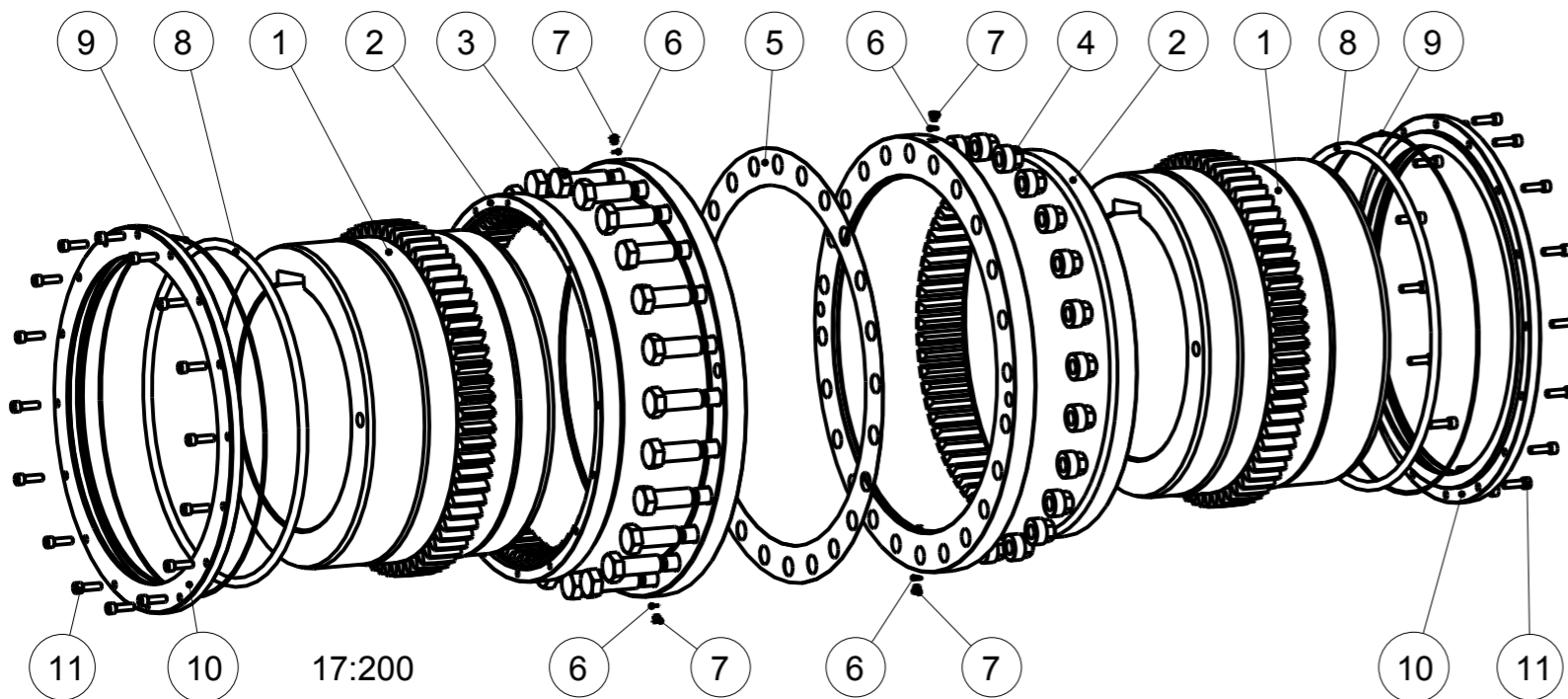

- Pos.11: DIN912 M10x35
 - Pos.9: O-Ring: 565x3
 - Pos.8: O-Ring: 522x14
 - Pos.7: Schraube / screw DIN 908: M10x1
 - Pos.6: Scheibe / disc DIN 7603: A10x13.5
- Schraubenanzugsmoment (Pos.3) $T_A = 1000\text{Nm}$ Drehmoment / torque $T_{KN} = 500000\text{ Nm}$
 screw tightening torque (Pos.3) $T_A = 1000\text{Nm}$ $T_{Kmax.} = 1000000\text{ Nm}$
ACHTUNG / ATTENTION
 Schrauben bei Auslieferung handfest angezogen.
 Screws are not tightened at delivery.



Oberflächenguete nach DIN ISO 1302 Reihe 2 Surface quality acc. to DIN ISO 1302 line 2		Schutzvermerk ISO 16016 beachten Note protection mark acc. to ISO 16016	
Allgemeintoleranzen nach DIN ISO 2768 - mH General tolerances acc. to DIN ISO 2768 - mH		Masstab Scale	1:5
		Format DIN Size	A3
GEARex 100 Ø390 Ø390 Bauart DB		 KTR-Kupplungstechnik GmbH D-48407 Rheine	
gezeichnet drawn	Werkstoff Material	Teilnummer Part number	Kz
Datum	30.08.11	DIN	Lfd.-Nr. Current number
Name	SCHP	Gewicht Weight	697.742
		M	543127
			0

Für Montage, Betrieb & Wartung, Betriebs-/ Montageanleitung KTR-N 40310 beachten.
 For assembly, operation & maintenance, observe operating-/ assembly instructions KTR-N 40310.