

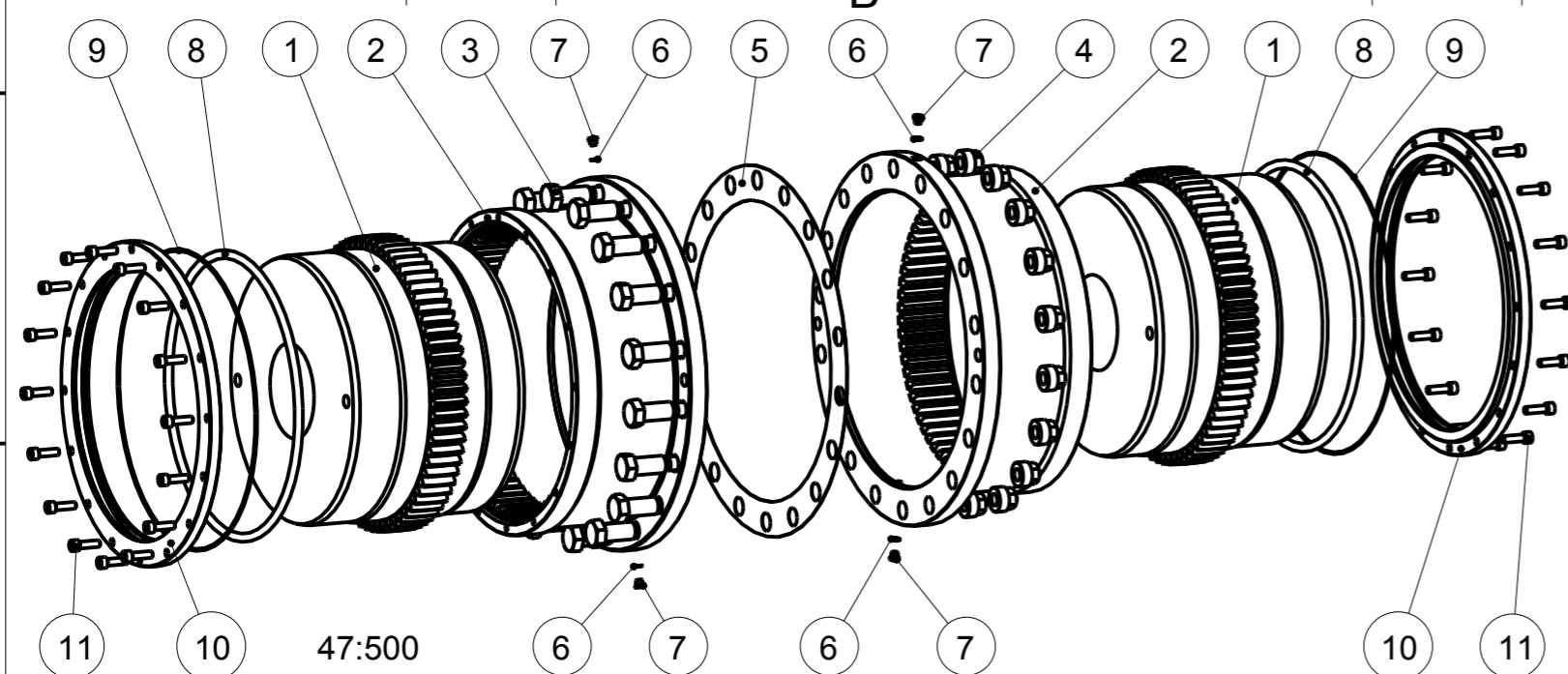

Pos.11: DIN912 M10x35  
 Pos.9: O-Ring: 435x3  
 Pos.8: O-Ring: 402x12  
 Pos.7: Schraube / screw DIN 908: M10x1  
 Pos.6: Scheibe / disc DIN 7603: A10x13.5  
 Schraubenanzugsmoment (Pos.3)  $T_A = 610\text{Nm}$   
 screw tightening torque (Pos.3)  $T_A = 610\text{Nm}$   
 Drehmoment / torque  $T_{KN} = 175000\text{ Nm}$   
 $T_{Kmax.} = 350000\text{ Nm}$   
**ACHTUNG / ATTENTION**  
 Schrauben bei Auslieferung handfest angezogen.  
 Screws are not tightened at delivery.



Für Montage, Betrieb & Wartung, Betriebs-/ Montageanleitung KTR-N 40310 beachten.  
 For assembly, operation & maintenance, observe operating-/ assembly instructions KTR-N 40310.

Oberflächenguete nach DIN ISO 1302 Reihe 2 Surface quality acc. to DIN ISO 1302 line 2		Schutzvermerk ISO 16016 beachten Note protection mark acc. to ISO 16016	
Allgemeintoleranzen nach DIN ISO 2768 - mH General tolerances acc. to DIN ISO 2768 - mH		Masstab Scale	1:4
		Format DIN Size	A3
<b>GEARex 80 Ø140 Ø140</b> Bauart DB		 KTR-Kupplungstechnik GmbH D-48407 Rheine	
gezeichnet drawn	Werkstoff Material	Teilnummer Part number	Kz
Datum	15.08.11	DIN	
Name	KU	Gewicht Weight	610.408
			M
		Lfd.-Nr. Current number	542039
		Index Change	0