

Pos.8: O-Ring: 67x3.5
 Pos.7: Schraube / screw DIN 7984: M6x10
 Pos.6: Scheibe / disc DIN 7603: A6.5x9.5

Schraubenanzugsmoment (Pos.3) $T_A = 15\text{ Nm}$
 screw tightening torque (Pos.3) $T_A = 15\text{ Nm}$

ACHTUNG / ATTENTION
 Schrauben bei Auslieferung handfest angezogen.
 Screws are not tightened at delivery.

Drehmoment / torque
 $T_{KN} = 930\text{ Nm}$
 $T_{Kmax.} = 1860\text{ Nm}$

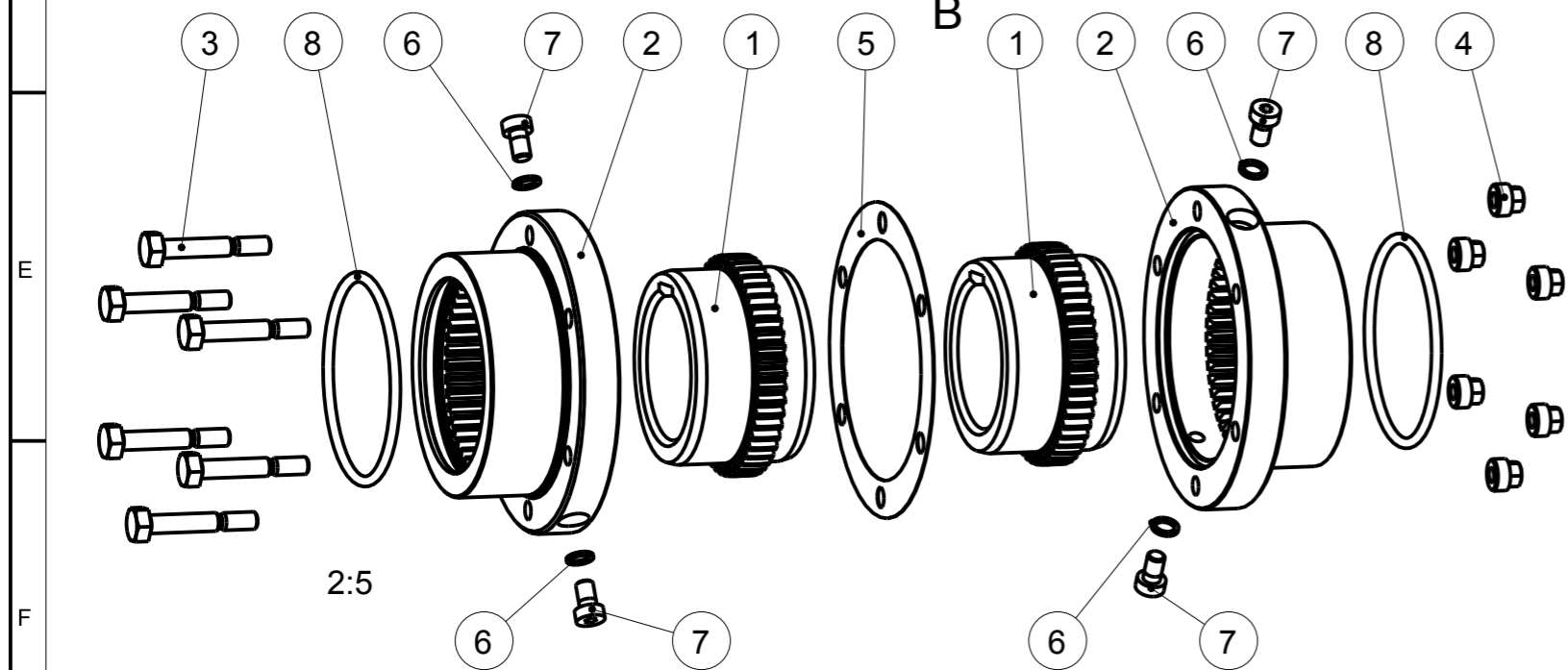

Für Montage, Betrieb & Wartung, Betriebs-/ Montageanleitung KTR-N 40310 beachten.
 For assembly, operation & maintenance, observe operating-/ assembly instructions KTR-N 40310.

Oberflächenguete nach DIN ISO 1302 Reihe 2 Surface quality acc. to DIN ISO 1302 line 2		Schutzvermerk ISO 16016 beachten Note protection mark acc. to ISO 16016			
Allgemeintoleranzen nach DIN ISO 2768 - mH General tolerances acc. to DIN ISO 2768 - mH		Masstab Scale	6:5	Format DIN Size	A3
GEARex 10 Ø50 Ø50 Bauart FAB			 KTR-Kupplungstechnik GmbH D-48407 Rheine		
gezeichnet drawn	Werkstoff Material	Teilnummer Part number	Kz	Lfd.-Nr. Current number	Index Change
Datum 30.08.11	DIN		M	543128	0
Name SCHP	Gewicht Weight	2.796			