

Teil 1 u. 2:  
 Oberfläche phosphatiert  
 Fertigbohrung, Nut und Gewinde blank  
 part 1 and 2:  
 surface protection phosphated  
 finish bore, keyway and thread  
 without phosphating

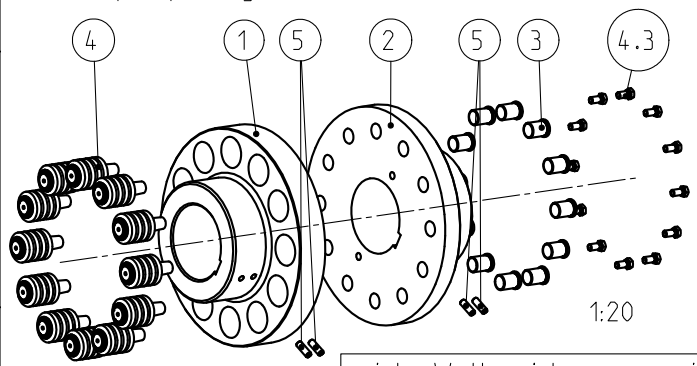

axiale Wellensicherung sowie Toleranzen der Welle / Nabe-Verbindung nach Kundenvorgabe  
 axial safety of hubs as well as tolerances of the shaft / hub-connection depending on costumers requirement

Nabenwerkstoff:  
 hub material:  
 EN-GJL-250

Max. Drehzahl / max. speed  $800 \text{ min}^{-1}$   
 Dyn. wuchten erforderlich / dyn. balanced required  
 Uebertragbares Drehmoment NBR 80 Shore A  
 Transmittable torque  
 $T_{KN} = 91480 \text{ Nm}$   
 $T_{Kmax} = 182960 \text{ Nm}$   
 Anzugsmoment Teil 4.3 M24  $T_A = 970 \text{ Nm}$   
 tightening torque part 4.3 M24  $T_A = 970 \text{ Nm}$   
 Massentraegheitsmoment / mass moment of inertia  
 $J_{ges} = 68.214641 \text{ kgm}^2$

\* Erforderliches Ausbaumaß / Drop-out center dimension

Oberflaechenguete nach DIN ISO 1302 Reihe 2 Surface quality acc. to DIN ISO 1302 line 2		Schutzvermerk ISO 16016 beachten Note protection mark acc. to ISO 16016	
Allgemeintoleranzen nach DIN ISO 2768 - mH General tolerances acc. to DIN ISO 2768-		Masstab Scale	1:10
		Format DIN Size	A3
<b>REVOLEX KX 265</b> Maßblatt		 KTR-Kupplungstechnik GmbH D-48407 Rheine	
gezeichnet drawn	Werkstoff Material	Teilnummer Part number	Kz
Datum 29.05.09	DIN		Lfd.-Nr. Current number
Name HN	Gewicht Weight	893.335	Index Change
			M
			491461
			0