

Max. Drehzahl / max. speed 1225 min^{-1}
 Dyn. wuchten erforderlich / dyn. balanced required
 Uebertragbares Drehmoment NBR 80 Shore A
 Transmittable torque NBR 80 Shore A
 $T_{KN} = 158800 \text{ Nm}$; $T_{Kmax} = 317600 \text{ Nm}$
 Massenträgheitsmoment / Mass moment of inertia
 $J_{ges} = 136.47664 \text{ kgm}^2$

Schraubenanzugsmoment Teil 4.3 / screw tightening torque part 4.3
 DIN EN ISO 4017-M24x90-10.9; $T_A = 970 \text{ Nm}$
 Klebesicherung im Gewinde; Kleber nach KTR-N 40011
 adhesive locking device in the thread; adhesive acc. to KTR standard 40011

* Erforderliches Ausbaumaß / Drop-out center dimension

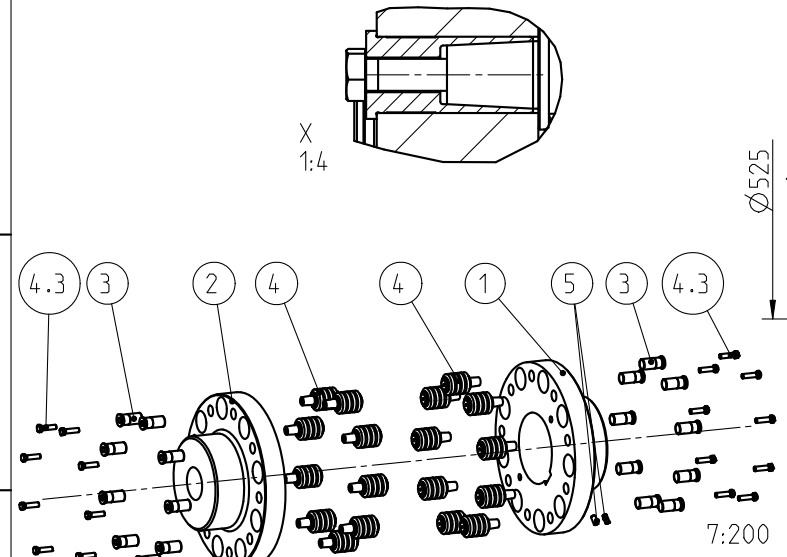

axiale Nabensicherung sowie Toleranzen der Welle / Nabe-Verbindung nach Kundenvorgabe
 axial safety of hubs as well as tolerances of the shaft / hub-connection depending on customers requirement

Nabenwerkstoff:
 hub material:
 C45

Oberflächengüte nach DIN ISO 1302 Reihe 2 Surface quality acc. to DIN ISO 1302 line 2		Schutzvermerk ISO 16016 beachten Note protection mark acc. to ISO 16016	
Allgemeintoleranzen nach DIN ISO 2768 - mH General tolerances acc. to DIN ISO 2768 - mH		Masstab Scale	1:10
		Format DIN Size	A3
REVOLEX KX 280-D Maßblatt			
gezeichnet drawn	Werkstoff Material	Teilnummer Part number	Kz
Datum 23.07.09	DIN		Lfd.-Nr. Current number
Name KB	Gewicht Weight	1435.687	Index Change
		M	493969
			0