

Teil 1 und 2:
Oberfläche phosphatiert
Fertigbohrung, Nut und Gewinde blank
part 1 and 2:
surface protection phosphated
finish bore, keyway and thread
without phosphating

Max. Drehzahl / max. speed 2000 min⁻¹
Dyn. wuchten erforderlich / dyn. balanced required
Übertragbares Drehmoment / Transmittable torque
NBR 80 Shore A
T_{KN} = 8650 Nm; T_{Kmax} = 17300 Nm
Massenträgheitsmoment / Mass moment of inertia
J_{ges} = 0.88861722 kgm²

Schraubenanzugsmoment Teil 3.3 / screw tightening torque part 3.3
DIN EN ISO 4017 - M10x50 - 10.9; T_A = 67 Nm

Klebesicherung im Gewinde; Kleber nach KTR-N 40011
adhesive locking device in the thread; adhesive acc. to KTR standard 40011

* Erforderliches Ausbaumaß / Drop-out center dimension

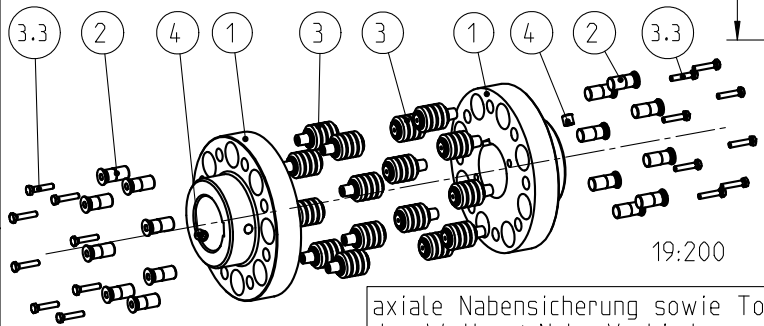

19:200

axiale Nabelsicherung sowie Toleranzen der Welle / Nabe-Verbindung nach Kundenvorgabe
axial safety of hubs as well as tolerances of the shaft / hub-connection depending on customers requirement

Nabenwerkstoff:
hub material:
EN-GJL-250

Oberflächengüte nach DIN ISO 1302 Reihe 2 Surface quality acc. to DIN ISO 1302 line 2		Schutzvermerk ISO 16016 beachten Note protection mark acc. to ISO 16016			
Allgemeintoleranzen nach DIN ISO 2768 - mH General tolerances acc. to DIN ISO 2768 - mH		Masstab Scale	13:50	Format DIN Size	A3
REVOLEX KX 105-D Maßblatt			 KTR-Kupplungstechnik GmbH D-48407 Rheine		
gezeichnet drawn	Werkstoff Material	Teilnummer Part number	Kz	Lfd.-Nr. Current number	Index Change
Datum 22.07.09	DIN		M	493859	0
Name KB	Gewicht Weight	68.324			