

Teil 1 und 2:
 Oberflaeche phosphatiert
 Fertigbohrung, Nut und Gewinde blank
 part 1 and 2:
 surface protection phosphated
 finish bore, keyway and thread
 without phosphating

Max. Drehzahl / max. speed 1800 min^{-1}
 Dyn. wuchten erforderlich / dyn. balanced required
 Uebertragbares Drehmoment / Transmittable torque
 NBR 80 Shore A
 $T_{KN} = 14110 \text{ Nm}; T_{Kmax} = 28220 \text{ Nm}$
 Massentraegheitsmoment / Mass moment of inertia
 $J_{ges} = 1.8330251 \text{ kgm}^2$

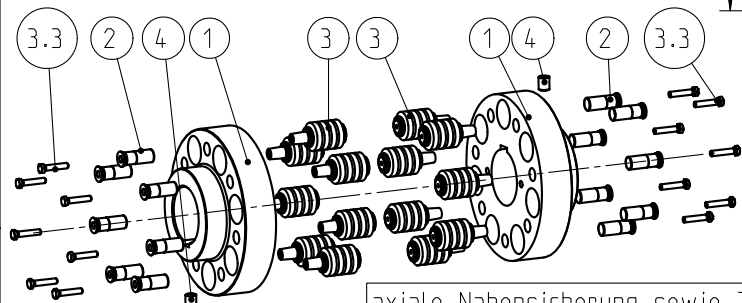

Nabenwerkstoff:
 hub material:
 EN-GJL-250

axiale Nabensicherung sowie Toleranzen
 der Welle / Nabe-Verbindung nach Kundenvorgabe
 axial safety of hubs as well as tolerances of the
 shaft / hub-connection depending on customers requirement

Schraubenanzugsmoment Teil 3.3 / screw tightening torque part 3.3
 DIN EN ISO 4017 - M12x60 - 10.9; $T_A = 115 \text{ Nm}$
 Klebersicherung im Gewinde; Kleber nach KTR-N 40011
 adhesive locking device in the thread; adhesive acc. to KTR standard 40011
 * Erforderliches Ausbaumaß / Drop-out center dimension

Oberflaechenguete nach DIN ISO 1302 Reihe 2 Surface quality acc. to DIN ISO 1302 line 2		Schutzvermerk ISO 16016 beachten Note protection mark acc. to ISO 16016	
Allgemeintoleranzen nach DIN ISO 2768 - mH General tolerances acc. to DIN ISO 2768 - mH		Masstab Scale	1:4
		Format DIN Size	A3
REVOLEX KX 120-D Maßblatt			
gezeichnet drawn	Werkstoff Material	Teilnummer Part number	Kz
Datum 23.07.09	DIN		Lfd.-Nr. Current number
Name KB	Gewicht Weight	107.713	Index Change
		M	493927
			0