

Schmiernippel  
lubricating nipples  
DIN 714.12-A M10x1

Schaltzitz gefettet  
engaging fit greased

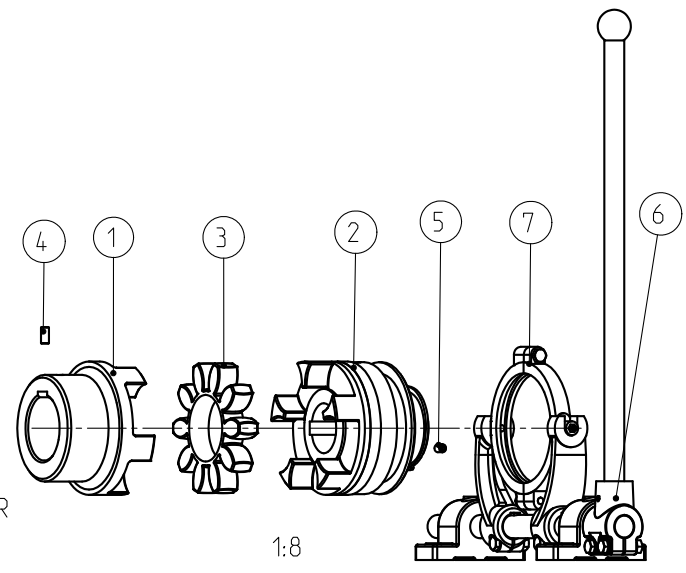

1:8

Drehmoment / Torque  
Zahnkranz / spider 92 Sh A T-PUR  
(Zahnkranz / spider 92 Sh A)  
 $T_{KN} = 2400 \text{ Nm}$   
 $T_{Kmax} = 4800 \text{ Nm}$

Teil 6 - Schaltgestaenge Gr. 4 / part 6 - shift linkage size 4  
Teil 7 - Schleifring Gr. 5.5 / part 7 - slip ring size 5.5

Eingestellte Schaltkraft 350 N / Shifting force 350 N

Schraubenanzugsmoment / screw tightening torque

A1 = M12,  $T_A = 86 \text{ Nm}$

A2 = M12,  $T_A = 86 \text{ Nm}$

1) = Standardeinbaumass / standard assembly dimension  
min. Einbaumass = 321 mm / min. assembly dimension = 321 mm

Oberflaechenguete nach DIN ISO 1302 Reihe 2 Surface quality acc. to DIN ISO 1302 line 2			Schutzvermerk nach DIN 34 beachten Note protection mark acc. to DIN 34			
Allgemeintoleranzen nach DIN ISO 2768 - mH General tolerances acc. to DIN ISO 2768-			Masstab Scale	1:4	Format DIN Size	A3
<b>ROTEX 90</b> SD			 KTR-Kupplungstechnik GmbH D-48407 Rheine			
gezeichnet drawn	Werkstoff Material	Teilnummer Part number	Kz	Lfd.-Nr. Current number	Index Change	
Datum 23.02.12	DIN		M	416453	1	
Name SCHP	Gewicht Weight	58.270				