

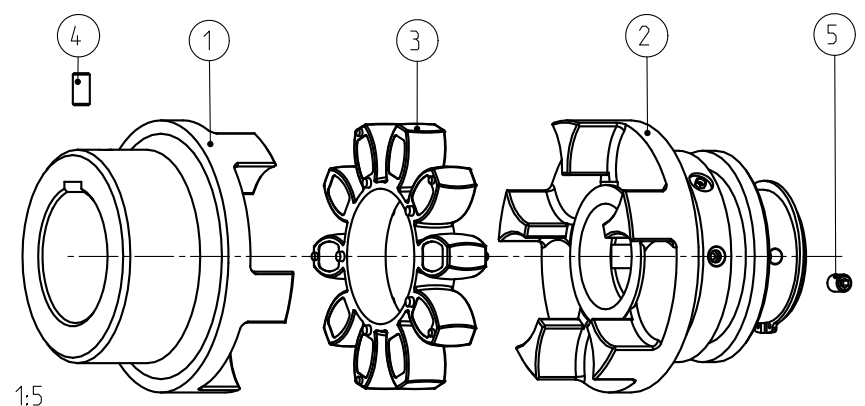

Drehmoment / Torque
 Zahnkranz / spider 92 Sh A T-PUR
 (Zahnkranz / spider 92 Sh A)
 $T_{KN} = 4800 \text{ Nm}$
 $T_{Kmax} = 9600 \text{ Nm}$

Eingestellte Schaltkraft 450 N / Shifting force 450 N

passend fuer Schaltgestaenge Gr. 4 und Schleifring 5.5
 suitable for shift linkage size 4 and slip ring size 5.5



Oberflaechenguete nach DIN ISO 1302 Reihe 2 Surface quality acc. to DIN ISO 1302 line 2		Schutzvermerk nach DIN 34 beachten Note protection mark acc. to DIN 34			
Allgemeintoleranzen nach DIN ISO 2768 - mH General tolerances acc. to DIN ISO 2768-		Masstab Scale	11:40	Format DIN Size	A3
ROTEX 110 SD			 KTR-Kupplungstechnik GmbH D-48407 Rheine		
gezeichnet drawn	Werkstoff Material	Teilnummer Part number	Kz	Lfd.-Nr. Current number	Index Change
Datum 17.02.12	DIN		M	416520	1
Name SCHP	Gewicht Weight	52.852			