

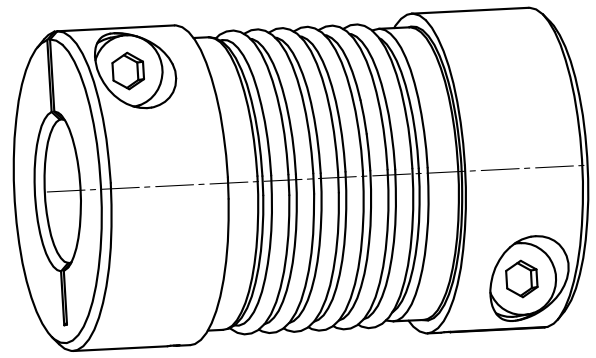

Schraubenanzugsmoment $T_A = 0.76 \text{ Nm}$
 screw tightening torque $T_A = 0.76 \text{ Nm}$

Drehmoment / Torque
 Balg / bellow
 $T_{KN} = 1.5 \text{ Nm}$

Massentraegheitsmoment (J_{ges}) der Kupplung (mit max. und min. Bohrung) 1.023359 kgmm^2
 mass moment of inertia (J_{ges}) of the kupplung (with max. and min. bore) 1.023359 kgmm^2



3:1

Oberflaechenguete nach DIN ISO 1302 Reihe 2 Surface quality acc. to DIN ISO 1302 line 2			Schutzvermerk ISO 16016 beachten Note protection mark acc. to ISO 16016			
Allgemeintoleranzen nach DIN ISO 2768 - mH General tolerances acc. to DIN ISO 2768 - mH			Masstab Scale	4:1	Format DIN Size	A3
TOOLFLEX 9 Bauart M			 KTR-Kupplungstechnik GmbH D-48407 Rheine			
gezeichnet drawn	Werkstoff Material	.	Teilnummer Part number	Kz	Lfd.-Nr. Current number	Index Change
Datum 09.10.06	DIN			M	449014	0
Name HF	Gewicht Weight	0.018				