

Massenträgheitsmoment $J_{ges.} = 0.0255329 \text{ kgm}^2$

Mass moment of inertia $J_{ges.} = 0.0255329 \text{ kgm}^2$

Drehmoment / Torque
Zahnkranz / spider 98 Sh A-GS

$T_{KN} = 410 \text{ Nm}$

$T_{Kmax} = 820 \text{ Nm}$

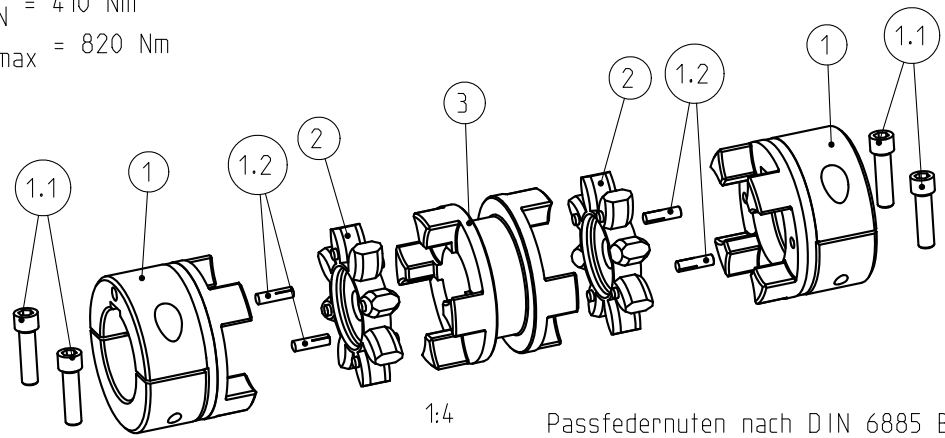

1:4
Passfedernuten nach DIN 6885 Bl. 1-JS9
keyways acc. to DIN 6885 sheet 1-JS9

zul. Radialverlagerungen ($\wedge Kr$)	
allowable radial displacements ($\wedge Kr$)	
bei $n = 1500 \text{ min}^{-1}$	bei $n = 3000 \text{ min}^{-1}$
at $n = 1500 \text{ rpm}$	at $n = 3000 \text{ rpm}$
$\wedge Kr = 1.4 \text{ mm}$	$\wedge Kr = 1.05 \text{ mm}$

Schraubenanzugsmoment (1.1) M12x45 DIN 912-12.9	$T_A = 120 \text{ Nm}$
screw tightening torque (1.1) M12x45 DIN 912-12.9	$T_A = 120 \text{ Nm}$

Oberflächengüte nach DIN ISO 1302 Reihe 2 Surface quality acc. to DIN ISO 1302 line 2		Schutzvermerk ISO 16016 beachten Note protection mark acc. to ISO 16016			
Allgemeintoleranzen nach DIN ISO 2768 - mH General tolerances acc. to DIN ISO 2768-		Masstab Scale	3:5	Format DIN Size	A3
ROTEX 55 - L=140 ZS-DKM-H			 KTR-Kupplungstechnik GmbH D-48407 Rheine		
gezeichnet drawn	Werkstoff Material	Teilnummer Part number	Kz	Lfd.-Nr. Current number	Index Change
Datum 22.10.07	DIN		M	424628	1
Name EG	Gewicht Weight	10.959			