

Massenträgheitsmoment $J_{ges.} = 0.02778077 \text{ kgm}^2$

Mass moment of inertia $J_{ges.} = 0.02778077 \text{ kgm}^2$

Drehmoment / Torque
Zahnkranz / spider 98 Sh A-GS

$T_{KN} = 410 \text{ Nm}$

$T_{Kmax} = 820 \text{ Nm}$

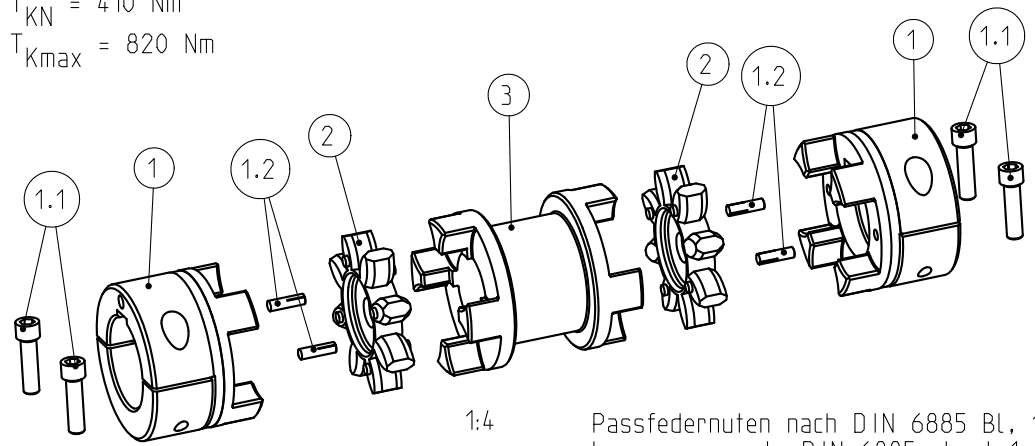

1:4 Passfedernuten nach DIN 6885 Bl. 1-JS9
keyways acc. to DIN 6885 sheet 1-JS9

zul. Radialverlagerungen ($\hat{K}r$)	
allowable radial displacements ($\hat{K}r$)	
bei $n = 1500 \text{ min}^{-1}$	bei $n = 3000 \text{ min}^{-1}$
at $n = 1500 \text{ rpm}$	at $n = 3000 \text{ rpm}$
$\hat{K}r = 2.1 \text{ mm}$	$\hat{K}r = 1.57 \text{ mm}$

Schraubenanzugsmoment (1.1) M12x45 DIN 912-12.9	$T_A = 120 \text{ Nm}$
screw tightening torque (1.1) M12x45 DIN 912-12.9	$T_A = 120 \text{ Nm}$

Oberflächengüte nach DIN ISO 1302 Reihe 2 Surface quality acc. to DIN ISO 1302 line 2		Schutzvermerk ISO 16016 beachten Note protection mark acc. to ISO 16016	
Allgemeintoleranzen nach DIN ISO 2768 - mH General tolerances acc. to DIN ISO 2768-		Masstab Scale	3:5
		Format DIN Size	A3

ROTEX 55 - L=180
ZS-DKM-H

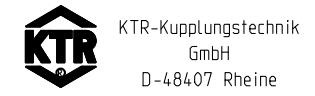

gezeichnet drawn	Werkstoff Material	Teilnummer Part number	Kz	Lfd.-Nr. Current number	Index Change
Datum 22.10.07	DIN				
Name EG	Gewicht Weight	12.293	M	424629	1